



Air Conditioning & Heating

GCH COMMERCIAL

Cooling Capacity:
87,000 — 116,000 BTU/h

Heating Capacity:
87,000 — 120,000 BTU/h

7½- TO 10-TON THREE-PHASE
PACKAGED HEAT PUMP

UP TO 11.5 EER & 3.4 COP

■ Contents

Nomenclature.....	2
Product Specifications.....	3
Expanded Cooling Data	4
Expanded Heating Data.....	10
Airflow Data.....	11
Heat Kit Electrical Data	14
Dimensions	15
Wiring Diagrams	19
Accessories	2



■ Standard Features

- R-410A chlorine-free refrigerant
- High-efficiency scroll compressors
- Suitable to operate at 125° F ambient temperature
- Two-stage cooling
- Copper tube / aluminum fin coils
- Power block for field wiring
- High-capacity, steel-cased filter drier
- Single-point entry
- 24-volt terminal strip
- Convertible airflow orientation
- Easy to service
- Built-in filter rack with standard 2" filters

■ Cabinet Features

- Heavy-gauge, galvanized-steel cabinet with UV-resistant powder-paint finish
- Full perimeter rail
- Sloped drain pan



NOMENCLATURE

	G	C	H	090	045	5	B	*	*	*	A	*																							
	1	2	3	4,5,6	7,8,9	10	11	12	13	14	15	16																							
Brand	Goodman																																		
Configuration	Commercial																																		
Application	Cooling																																		
Nominal Cooling Capacity	<table border="1"> <tr> <td>036</td> <td>3 Tons</td> <td>102</td> <td>8½ Tons</td> </tr> <tr> <td>048</td> <td>4 Tons</td> <td>120</td> <td>10 Tons</td> </tr> <tr> <td>060</td> <td>5 Tons</td> <td>180</td> <td>15 Tons</td> </tr> <tr> <td>072</td> <td>6 Tons</td> <td>240</td> <td>20 Tons</td> </tr> <tr> <td>090</td> <td>7½ Tons</td> <td></td> <td></td> </tr> </table>												036	3 Tons	102	8½ Tons	048	4 Tons	120	10 Tons	060	5 Tons	180	15 Tons	072	6 Tons	240	20 Tons	090	7½ Tons					
036	3 Tons	102	8½ Tons																																
048	4 Tons	120	10 Tons																																
060	5 Tons	180	15 Tons																																
072	6 Tons	240	20 Tons																																
090	7½ Tons																																		
Nominal Heating Capacity	<table border="1"> <thead> <tr> <th>Gas/Electric</th> <th colspan="4">A/C H/P Factory-Installed Electric Heat</th> </tr> </thead> <tbody> <tr> <td>180</td> <td>180,000 BTU/h</td> <td>XXX</td> <td>No Heat</td> <td>030</td> <td>30 kW</td> </tr> <tr> <td>300</td> <td>300,000 BTU/h</td> <td>016</td> <td>15 kW</td> <td>045</td> <td>44 kW</td> </tr> <tr> <td>350</td> <td>350,000 BTU/h</td> <td></td> <td></td> <td></td> <td></td> </tr> </tbody> </table> <p>See product specifications for heat size(s) available for each capacity.</p>												Gas/Electric	A/C H/P Factory-Installed Electric Heat				180	180,000 BTU/h	XXX	No Heat	030	30 kW	300	300,000 BTU/h	016	15 kW	045	44 kW	350	350,000 BTU/h				
Gas/Electric	A/C H/P Factory-Installed Electric Heat																																		
180	180,000 BTU/h	XXX	No Heat	030	30 kW																														
300	300,000 BTU/h	016	15 kW	045	44 kW																														
350	350,000 BTU/h																																		
Revision Levels	Major & Minor																																		
Factory-Installed Options	X No Options																																		
Factory-Installed Options	X Standard Aluminized Heat Exchanger S Stainless-Steel Heat Exchanger																																		
Factory-Installed Options	X No Options																																		
Supply Fan/Drive Type/Motor	B Belt Drive																																		
Voltage	<table border="1"> <tr> <td>1</td> <td>208-230/1/60</td> <td>4</td> <td>460/3/60</td> </tr> <tr> <td>3</td> <td>208-230/3/60</td> <td>5</td> <td>400/3/50</td> </tr> </table>												1	208-230/1/60	4	460/3/60	3	208-230/3/60	5	400/3/50															
1	208-230/1/60	4	460/3/60																																
3	208-230/3/60	5	400/3/50																																

ACCESSORIES

FILED-INSTALLED ITEM #	DESCRIPTION	FITS MODEL SIZES
DDNECNJ90150	Downflow Economizer	7½-10 tons
DHZECNJ90150	Horizontal Economizer	7½-10 tons
	Electric Heat Kits	All Models
HSKT090	High-Static Kit	7½ tons
HSKT120	High-Static Kit	10 tons

PRODUCT SPECIFICATIONS

	GCH090 ***5B***A*	GCH102 ***5B***A*	GCH120 ***5B***A*
Cooling Capacity			
Total BTU/h	87,000	97,000	116,000
Sensible BTU/h	65,700	73,440	84,700
EER / IEER	11.5 / 11.5	11.1 / 11.2	11.3 / 11.5
Decibels	83	83	83
Heating Capacity			
BTU/h / COP (47° F)	87,000 / 3.4	102,000 / 3.4	120,000 / 3.4
BTU/h / COP (17° F)	53,000 / 2.4	55,500 / 2.25	56,000 / 2.4
Evaporator Motor / Coil			
Motor Type	Belt Drive	Belt Drive	Belt Drive
Indoor Nominal CFM	3,000	3,400	4,000
Indoor Motor FLA (Cooling)	4.6	4.6	4.6
Horsepower - RPM	3.0 - 1,725	3.0 - 1,725	3.0 - 1,725
Piston Size (Cooling)	0.074	0.078	0.086
(#) Filter Size	(4) 16" x 24" x 2"	(4) 16" x 24" x 2"	(4) 16" x 24" x 2"
Drain Size (NPT)	¾"	¾"	¾"
R-410A Refrigerant Charge: Cir #1/ #2 (oz.)	225 / 225	195 / 195	194 / 194
Evaporator Coil Face Area (ft ²)	10.2	10.2	10.2
Rows Deep / Fins per Inch	4 / 16	4 / 14	4 / 14
Belt Drive Evap Fan Data			
# of Wheels (D x W)	1 (15" x 12")	1 (15" x 15")	1 (15" x 15")
Motor Sheave / Blower Sheave	VL40 / AK59	VL40 / AK59	VL40 / AK59
Belt	AX48	AX46	AX46
Condenser Fan / Coil			
Quantity of condenser Fan Motors	2	2	2
Horsepower - RPM	½ - 1,050	½ - 1,050	½ - 1,050
Fan Diameter / # Fan Blades	22 / 3	22 / 3	22 / 3
Outdoor Expansion Device	0.052	0.059	0.064
Outdoor Nominal CFM	7,200	7,200	7,200
Face Area (ft ²)	32.4	32.4	32.4
# Coils / Rows Deep - Fins per Inch	2 X 2 - 20±1	2 X 2 - 22±1	2 X 2 - 22±1
Compressor			
Quantity / Type / Stage	2 / Scroll / 1	2 / Scroll / 1	2 / Scroll / 1
Compressor RLA / LRA	6.3/55.0	7.8/52.0	10.9/64.0
Electrical Data			
Voltage / Phase / Frequency	400 / 3 / 50	400 / 3 / 50	400 / 3 / 50
Max External Static	1.0"	1.0"	1.0"
Outdoor Fan HP / FLA	½ / .85 (2)	½ / .85 (2)	½ / .85 (2)
Total Unit Amps	18.9	21.9	28.1
Min. Circuit Ampacity ¹	20.5	23.9	30.8
Max. Overcurrent Protection (amps) ²	25	30	40
Entrance Power Supply & Control Voltage	Locating Dimple	Locating Dimple	Locating Dimple
OPERATING WEIGHT (LBS)	1135	1285	1285
SHIP WEIGHT (LBS)	1175	1310	1310

¹ Wire size should be determined in accordance with National Electrical Codes. Extensive wire runs will require larger wire sizes.

² May use fuses or HACR-type circuit breakers of the same size as noted.

NOTE: Always check the S&R plate for electrical data on the unit being installed.

COOLING DATA — 7½ TONS

IDB		OUTDOOR AMBIENT TEMPERATURE												ENTERING INDOOR WET BULB TEMPERATURE																	
		65				75				85				95				105				115									
		59	63	67	71	59	63	67	71	59	63	67	71	59	63	67	71	59	63	67	71	59	63	67	71						
70	3375	MBh	85.3	88.4	96.8	-	83.3	86.3	94.6	-	81.3	84.3	92.3	-	79.3	82.2	90.1	-	75.3	78.1	85.6	-	75.3	78.1	85.6	-	69.8	72.3	79.3	-	
		S/T	0.75	0.63	0.44	-	0.78	0.65	0.45	-	0.80	0.67	0.46	-	0.83	0.69	0.48	-	0.86	0.72	0.50	-	0.86	0.72	0.50	-	0.86	0.72	0.50	-	
		ΔT	17	15	11	-	18	15	12	-	18	15	12	-	18	15	12	-	18	15	12	-	18	15	12	-	16	14	11	-	
	3000	kW	5.67	5.78	5.95	-	6.07	6.19	6.38	-	6.43	6.56	6.76	-	6.74	6.88	7.10	-	7.01	7.16	7.38	-	7.01	7.16	7.38	-	7.24	7.40	7.63	-	
		Amps	12.5	12.7	12.9	-	13.1	13.4	13.7	-	13.9	14.1	14.5	-	14.6	14.8	15.2	-	15.2	15.5	15.9	-	15.2	15.5	15.9	-	15.9	16.2	16.6	-	
		HI PR	234	252	266	-	262	282	298	-	298	321	339	-	340	366	386	-	382	411	434	-	382	411	434	-	422	454	480	-	
	2400	LO PR	108	115	126	-	114	122	133	-	119	126	138	-	125	133	145	-	131	139	152	-	131	139	152	-	135	144	157	-	
		MBh	82.8	85.8	94.0	-	80.8	83.8	91.8	-	78.9	81.8	89.6	-	77.0	79.8	87.4	-	73.1	75.8	83.1	-	73.1	75.8	83.1	-	67.8	70.2	76.9	-	
		S/T	0.72	0.60	0.42	-	0.74	0.62	0.43	-	0.76	0.64	0.44	-	0.79	0.66	0.46	-	0.82	0.68	0.47	-	0.82	0.68	0.47	-	0.82	0.69	0.48	-	
	75	3375	ΔT	18	16	12	-	18	16	12	-	18	16	12	-	19	16	12	-	19	16	12	-	18	16	12	-	17	15	11	-
			kW	5.63	5.74	5.90	-	6.03	6.15	6.33	-	6.38	6.51	6.71	-	6.69	6.83	7.04	-	6.96	7.10	7.33	-	6.96	7.10	7.33	-	7.19	7.34	7.57	-
			Amps	12.4	12.6	12.9	-	13.1	13.3	13.6	-	13.8	14.1	14.4	-	14.5	14.7	15.1	-	15.1	15.4	15.8	-	15.1	15.4	15.8	-	15.8	16.1	16.5	-
3000		HI PR	231	249	263	-	260	279	295	-	295	318	336	-	336	362	382	-	378	407	430	-	378	407	430	-	418	450	475	-	
		LO PR	107	114	124	-	113	120	132	-	118	125	137	-	124	132	144	-	130	138	150	-	130	138	150	-	134	143	156	-	
		MBh	76.4	79.2	86.8	-	74.6	77.3	84.7	-	72.8	75.5	82.7	-	71.1	73.7	80.7	-	67.5	70.0	76.7	-	67.5	70.0	76.7	-	62.5	64.8	71.0	-	
2400		S/T	0.69	0.58	0.40	-	0.72	0.60	0.42	-	0.74	0.61	0.43	-	0.76	0.63	0.44	-	0.79	0.66	0.46	-	0.79	0.66	0.46	-	0.80	0.66	0.46	-	
		ΔT	20	18	13	-	21	18	13	-	21	18	13	-	21	18	14	-	20	18	13	-	20	18	13	-	19	16	13	-	
		kW	5.50	5.61	5.77	-	5.89	6.01	6.19	-	6.23	6.36	6.55	-	6.54	6.67	6.88	-	6.79	6.94	7.15	-	6.79	6.94	7.15	-	7.02	7.16	7.39	-	
3375		Amps	12.2	12.4	12.6	-	12.8	13.0	13.3	-	13.6	13.8	14.1	-	14.2	14.4	14.8	-	14.8	15.1	15.5	-	14.8	15.1	15.5	-	15.5	15.7	16.1	-	
		HI PR	224	242	255	-	252	271	286	-	286	308	326	-	326	351	371	-	367	395	417	-	367	395	417	-	406	436	461	-	
		LO PR	104	111	121	-	110	117	128	-	114	121	133	-	120	128	139	-	126	134	146	-	126	134	146	-	130	138	151	-	
75	3375	MBh	86.7	89.3	96.6	103.7	84.7	87.2	94.4	101.3	82.7	85.1	92.1	98.9	80.6	83.0	89.9	96.5	76.6	78.9	85.4	91.6	76.6	78.9	85.4	91.6	71.0	73.1	79.1	84.9	
		S/T	0.86	0.77	0.58	0.37	0.89	0.79	0.60	0.39	0.91	0.81	0.62	0.40	0.94	0.84	0.64	0.41	0.97	0.87	0.66	0.42	0.97	0.87	0.66	0.42	0.98	0.88	0.67	0.43	
		ΔT	20	19	15	11	20	19	15	11	20	19	15	11	21	19	16	11	20	19	15	11	20	19	15	11	19	18	14	10	
	3000	kW	5.71	5.82	5.99	6.17	6.12	6.24	6.43	6.63	6.48	6.61	6.82	7.03	6.80	6.94	7.16	7.38	7.07	7.22	7.44	7.68	7.07	7.22	7.44	7.68	7.30	7.46	7.69	7.94	
		Amps	12.5	12.7	13.0	13.4	13.2	13.4	13.7	14.1	14.0	14.2	14.6	15.0	14.7	14.9	15.3	15.7	15.3	15.6	16.0	16.4	15.3	15.6	16.0	16.4	16.0	16.3	16.7	17.2	
		HI PR	236	254	268	280	265	285	301	314	301	324	342	357	343	369	390	407	386	415	439	458	386	415	439	458	427	459	485	506	
	2400	LO PR	109	116	127	135	116	123	134	143	120	128	139	149	126	134	146	156	132	141	154	163	132	141	154	163	137	145	159	169	
		MBh	84.2	86.7	93.8	100.7	82.2	84.6	91.6	98.3	80.3	82.6	89.4	96.0	78.3	80.6	87.3	93.7	74.4	76.6	82.9	89.0	74.4	76.6	82.9	89.0	68.9	70.9	76.8	82.4	
		S/T	0.82	0.73	0.55	0.36	0.85	0.76	0.57	0.37	0.87	0.78	0.59	0.38	0.90	0.80	0.61	0.39	0.93	0.83	0.63	0.40	0.93	0.83	0.63	0.40	0.94	0.84	0.63	0.41	
	75	3375	ΔT	21	19	16	11	21	20	16	11	21	20	16	11	21	20	16	11	21	20	16	11	21	20	16	11	20	18	15	10
			kW	5.67	5.78	5.95	6.13	6.07	6.19	6.38	6.58	6.43	6.56	6.76	6.97	6.75	6.89	7.10	7.32	7.01	7.16	7.39	7.62	7.01	7.16	7.39	7.62	7.25	7.40	7.63	7.88
			Amps	12.5	12.7	12.9	13.3	13.1	13.4	13.7	14.0	13.9	14.1	14.5	14.9	14.6	14.8	15.2	15.6	15.2	15.5	15.9	16.3	15.2	15.5	15.9	16.3	15.9	16.2	16.6	17.1
3000		HI PR	234	252	266	277	262	282	298	311	298	321	339	354	340	366	386	403	382	411	434	453	382	411	434	453	422	454	480	501	
		LO PR	108	115	126	134	114	122	133	141	119	126	138	147	125	133	145	154	131	139	152	162	131	139	152	162	135	144	157	167	
		MBh	77.7	80.0	86.6	92.9	75.9	78.1	84.6	90.8	74.1	76.3	82.6	88.6	72.3	74.4	80.5	86.4	68.7	70.7	76.5	82.1	68.7	70.7	76.5	82.1	63.6	65.5	70.9	76.1	
2400		S/T	0.79	0.70	0.53	0.34	0.82	0.73	0.55	0.36	0.84	0.75	0.57	0.36	0.86	0.77	0.58	0.38	0.90	0.80	0.61	0.39	0.90	0.80	0.61	0.39	0.90	0.81	0.61	0.39	
		ΔT	23	22	18	12	24	22	18	12	24	22	18	12	24	22	18	12	24	22	18	12	24	22	18	12	22	20	17	11	
		kW	5.54	5.65	5.81	5.99	5.93	6.05	6.23	6.42	6.28	6.41	6.60	6.81	6.59	6.72	6.93	7.15	6.85	6.99	7.21	7.44	6.85	6.99	7.21	7.44	7.07	7.22	7.45	7.69	
3375		Amps	12.3	12.4	12.7	13.0	12.9	13.1	13.4	13.7	13.6	13.9	14.2	14.6	14.3	14.5	14.9	15.3	14.9	15.2	15.6	16.0	14.9	15.2	15.6	16.0	15.6	15.8	16.2	16.7	
		HI PR	227	244	258	269	254	274	289	302	289	311	329	343	330	355	375	391	371	399	421	439	371	399	421	439	410	441	466	486	
		LO PR	105	112	122	130	111	118	129	137	115	123	134	143	121	129	141	150	127	135	147	157	127	135	147	157	131	140	153	162	

IDB: Entering Indoor Dry Bulb Temperature
 High and low pressures are measured at the liquid and suction access fittings.
 Shaded area reflects ACCA (TVA) Rating Conditions
 Design Superheat 7.4± °F, Design Subcooling 12.±2 °F pressures measured @ the suction and liquid service ports, AHRI 95 test conditions
 Amps: Unit amps (comp.+ evaporator+ condenser fan motors)

COOLING DATA — 7½ TONS (CONT.)

IDB		OUTDOOR AMBIENT TEMPERATURE																								
		65				75				85				95				105				115				
		59	63	67	71	59	63	67	71	59	63	67	71	59	63	67	71	59	63	67	71	59	63	67	71	
		ENTERING INDOOR WET BULB TEMPERATURE																								
		MBh	88.2	90.2	96.3	103.0	86.2	88.1	94.1	100.6	84.1	86.0	91.9	98.2	82.1	83.9	89.6	95.8	78.0	79.7	85.1	91.0	72.2	73.8	78.9	84.3
		S/T	0.94	0.88	0.72	0.54	1.00	0.91	0.74	0.56	1.00	0.94	0.76	0.57	1.00	0.97	0.79	0.59	1.00	1.00	0.82	0.61	1.00	1.00	0.82	0.62
		ΔT	23	22	19	15	23	22	19	15	23	22	19	15	22	22	19	15	21	22	19	15	20	20	18	14
3375		kW	5.75	5.87	6.04	6.22	6.17	6.29	6.48	6.68	6.53	6.66	6.87	7.08	6.85	7.00	7.21	7.44	7.13	7.28	7.50	7.75	7.36	7.52	7.76	8.01
		Amps	12.6	12.8	13.1	13.4	13.3	13.5	13.8	14.2	14.1	14.3	14.7	15.1	14.8	15.0	15.4	15.8	15.4	15.7	16.1	16.6	16.1	16.4	16.8	17.3
		HI PR	238	257	271	283	268	288	304	317	304	328	346	361	347	373	394	411	390	420	443	462	431	464	490	511
		LO PR	110	118	128	137	117	124	136	144	121	129	141	150	127	136	148	158	134	142	155	165	138	147	160	171
		MBh	85.7	87.5	93.5	100.0	83.7	85.5	91.4	97.7	81.7	83.5	89.2	95.3	79.7	81.4	87.0	93.0	75.7	77.4	82.7	88.4	70.1	71.7	76.6	81.8
80		S/T	0.90	0.84	0.68	0.51	0.93	0.87	0.71	0.53	0.95	0.89	0.73	0.54	0.98	0.92	0.75	0.56	1.00	0.96	0.78	0.58	1.00	0.96	0.78	0.59
		ΔT	24	23	20	16	24	23	20	16	24	23	20	16	24	23	20	16	23	22	20	16	21	21	18	15
		kW	5.71	5.82	5.99	6.17	6.12	6.24	6.43	6.63	6.48	6.61	6.82	7.03	6.80	6.94	7.16	7.38	7.07	7.22	7.45	7.68	7.30	7.46	7.69	7.94
		Amps	12.5	12.7	13.0	13.4	13.2	13.4	13.7	14.1	14.0	14.2	14.6	15.0	14.7	14.9	15.3	15.7	15.3	15.6	16.0	16.4	16.0	16.3	16.7	17.2
		HI PR	236	254	268	280	265	285	301	314	301	324	342	357	343	369	390	407	386	415	439	458	427	459	485	506
	LO PR	109	116	127	135	116	123	134	143	120	128	139	149	126	134	147	156	132	141	154	164	137	145	159	169	
2400		MBh	79.1	80.8	86.3	92.3	77.2	78.9	84.3	90.1	75.4	77.0	82.3	88.0	73.6	75.2	80.3	85.8	69.9	71.4	76.3	81.5	64.7	66.1	70.7	75.5
		S/T	0.86	0.81	0.66	0.49	0.90	0.84	0.68	0.51	0.92	0.86	0.70	0.52	0.95	0.89	0.72	0.54	0.98	0.92	0.75	0.56	0.99	0.93	0.76	0.57
		ΔT	26	25	22	17	26	25	22	18	27	25	22	18	27	26	22	18	26	25	22	18	25	24	20	16
		kW	5.58	5.69	5.86	6.03	5.98	6.10	6.28	6.47	6.33	6.46	6.66	6.86	6.64	6.78	6.99	7.21	6.90	7.05	7.27	7.50	7.13	7.28	7.51	7.75
		Amps	12.3	12.5	12.8	13.1	13.0	13.2	13.5	13.8	13.7	14.0	14.3	14.7	14.4	14.6	15.0	15.4	15.0	15.3	15.7	16.1	15.7	16.0	16.3	16.8
	HI PR	229	246	260	271	257	277	292	305	292	315	332	346	333	358	378	395	375	403	426	444	414	445	470	490	
	LO PR	106	113	123	131	112	119	130	139	116	124	135	144	122	130	142	151	128	136	149	159	133	141	154	164	
3375		MBh	89.8	91.5	95.8	102.3	87.7	89.4	93.6	99.9	85.6	87.3	91.4	97.5	83.5	85.1	89.2	95.1	79.3	80.9	84.7	90.4	73.5	74.9	78.5	83.7
		S/T	0.98	0.95	0.86	0.70	1.00	0.98	0.89	0.72	1.00	1.00	0.91	0.74	1.00	1.00	0.94	0.76	1.00	1.00	0.98	0.79	1.00	1.00	0.98	0.80
		ΔT	24	24	22	19	24	24	23	20	23	24	23	20	23	23	23	20	22	22	23	20	22	20	21	18
		kW	5.79	5.91	6.08	6.27	6.21	6.34	6.53	6.73	6.58	6.72	6.92	7.14	6.91	7.05	7.27	7.50	7.18	7.33	7.56	7.81	7.42	7.58	7.82	8.07
		Amps	12.7	12.9	13.2	13.5	13.4	13.6	13.9	14.3	14.2	14.4	14.8	15.2	14.9	15.1	15.5	15.9	15.5	15.8	16.2	16.7	16.2	16.5	16.9	17.4
	HI PR	241	259	274	285	270	291	307	320	307	331	349	364	350	377	398	415	394	424	448	467	435	468	495	516	
	LO PR	112	119	130	138	118	125	137	146	122	130	142	152	129	137	149	159	135	143	157	167	139	148	162	173	
85		MBh	87.2	88.9	93.1	99.3	85.1	86.8	90.9	97.0	83.1	84.7	88.7	94.7	81.1	82.7	86.6	92.4	77.0	78.5	82.2	87.7	71.4	72.7	76.2	81.3
		S/T	0.94	0.91	0.82	0.66	0.97	0.94	0.85	0.69	1.00	0.96	0.87	0.71	1.00	0.99	0.90	0.73	1.00	1.00	0.93	0.76	1.00	1.00	0.94	0.76
		ΔT	25	25	23	20	25	25	24	20	25	25	24	20	25	25	24	21	24	24	23	20	22	22	22	19
		kW	5.75	5.87	6.04	6.22	6.17	6.29	6.48	6.68	6.53	6.66	6.87	7.08	6.85	7.00	7.21	7.44	7.13	7.28	7.50	7.75	7.36	7.52	7.76	8.01
		Amps	12.6	12.8	13.1	13.4	13.3	13.5	13.8	14.2	14.1	14.3	14.7	15.1	14.8	15.0	15.4	15.8	15.4	15.7	16.1	16.6	16.1	16.4	16.8	17.3
	HI PR	238	257	271	283	268	288	304	317	304	328	346	361	347	373	394	411	390	420	443	462	431	464	490	511	
	LO PR	110	118	128	137	117	124	136	144	121	129	141	150	127	136	148	158	134	142	155	165	138	147	160	171	
2400		MBh	80.5	82.0	85.9	91.6	78.6	80.1	83.9	89.5	76.7	78.2	81.9	87.4	74.8	76.3	79.9	85.2	71.1	72.5	75.9	81.0	65.9	67.1	70.3	75.0
		S/T	0.91	0.87	0.79	0.64	0.94	0.91	0.82	0.66	0.96	0.93	0.84	0.68	0.99	0.96	0.86	0.70	1.00	0.99	0.90	0.73	1.00	1.00	0.91	0.73
		ΔT	28	27	26	22	28	28	26	23	28	28	26	23	28	28	26	23	27	28	26	23	25	26	24	21
		kW	5.62	5.73	5.90	6.08	6.02	6.15	6.33	6.52	6.38	6.51	6.71	6.92	6.69	6.83	7.04	7.26	6.96	7.10	7.32	7.56	7.19	7.34	7.57	7.81
		Amps	12.4	12.6	12.9	13.2	13.1	13.3	13.6	13.9	13.8	14.0	14.4	14.8	14.5	14.7	15.1	15.5	15.1	15.4	15.8	16.2	15.8	16.1	16.5	16.9
	HI PR	231	249	263	274	260	279	295	308	295	318	335	350	336	362	382	399	378	407	430	448	418	450	475	495	
	LO PR	107	114	124	133	113	120	131	140	118	125	137	146	124	131	144	153	130	138	150	160	134	143	156	166	

IDB: Entering Indoor Dry Bulb Temperature
 High and low pressures are measured at the liquid and suction access fittings.
 Shaded area reflects AHRI Rating Conditions
 Design Superheat 7.4± °F, Design Subcooling 12.±2 °F pressures measured @ the suction and liquid service ports, AHRI 95 test conditions
 Amps: Unit amps (comp.+ evaporator + condenser fan motors)

COOLING DATA — 8½ TONS

IDB		OUTDOOR AMBIENT TEMPERATURE																											
		65				75				85				95				105				115							
		59	63	67	71	59	63	67	71	59	63	67	71	59	63	67	71	59	63	67	71	59	63	67	71				
		ENTERING INDOOR WET BULB TEMPERATURE																											
		AIRFLOW																											
3825	MBh	95.1	98.5	107.9	-	92.8	96.2	105.4	-	90.6	93.9	102.9	-	88.4	91.6	100.4	-	84.0	87.1	95.4	-	84.0	87.1	95.4	-	84.0	87.1	95.4	-
	S/T	0.77	0.64	0.44	-	0.80	0.67	0.46	-	0.82	0.68	0.47	-	0.84	0.70	0.49	-	0.88	0.73	0.51	-	0.88	0.73	0.51	-	0.88	0.73	0.51	-
	ΔT	18	15	12	-	18	15	12	-	18	15	12	-	18	16	12	-	18	15	12	-	18	15	12	-	17	14	11	-
	kW	6.44	6.57	6.76	-	6.90	7.04	7.26	-	7.31	7.46	7.69	-	7.67	7.83	8.08	-	7.98	8.15	8.41	-	7.98	8.15	8.41	-	8.24	8.42	8.69	-
	Amps	13.2	13.4	13.7	-	13.9	14.1	14.5	-	14.7	15.0	15.3	-	15.4	15.7	16.1	-	16.2	16.4	16.8	-	16.2	16.4	16.8	-	16.9	17.2	17.6	-
70	HI PR	234	252	266	-	262	282	298	-	298	321	339	-	340	366	386	-	382	411	434	-	382	411	434	-	422	454	480	-
	LO PR	108	115	126	-	114	122	133	-	119	126	138	-	125	133	145	-	131	139	152	-	131	139	152	-	135	144	157	-
	MBh	92.3	95.6	104.8	-	90.1	93.4	102.4	-	88.0	91.2	99.9	-	85.8	89.0	97.5	-	81.6	84.5	92.6	-	81.6	84.5	92.6	-	75.5	78.3	85.8	-
	S/T	0.73	0.61	0.42	-	0.76	0.63	0.44	-	0.78	0.65	0.45	-	0.80	0.67	0.47	-	0.83	0.70	0.48	-	0.83	0.70	0.48	-	0.84	0.70	0.49	-
	ΔT	18	16	12	-	19	16	12	-	19	16	12	-	19	16	12	-	19	16	12	-	18	16	12	-	17	15	11	-
2720	kW	6.39	6.52	6.71	-	6.85	6.99	7.20	-	7.26	7.41	7.63	-	7.61	7.77	8.01	-	7.92	8.08	8.34	-	7.92	8.08	8.34	-	8.18	8.35	8.62	-
	Amps	13.1	13.3	13.6	-	13.8	14.0	14.4	-	14.6	14.9	15.2	-	15.3	15.6	16.0	-	16.0	16.3	16.7	-	16.0	16.3	16.7	-	16.7	17.0	17.5	-
	HI PR	231	249	263	-	260	279	295	-	295	318	336	-	336	362	382	-	378	407	430	-	378	407	430	-	418	450	475	-
	LO PR	107	114	124	-	113	120	132	-	118	125	137	-	124	132	144	-	130	138	150	-	130	138	150	-	134	143	156	-
	MBh	85.2	88.3	96.7	-	83.2	86.2	94.5	-	81.2	84.2	92.2	-	79.2	82.1	90.0	-	75.3	78.0	85.5	-	75.3	78.0	85.5	-	69.7	72.3	79.2	-
75	S/T	0.71	0.59	0.41	-	0.73	0.61	0.42	-	0.75	0.63	0.43	-	0.78	0.65	0.45	-	0.80	0.67	0.47	-	0.80	0.67	0.47	-	0.81	0.68	0.47	-
	ΔT	20	18	13	-	21	18	14	-	21	18	14	-	21	18	14	-	20	18	13	-	20	18	13	-	19	17	13	-
	kW	6.49	6.62	6.81	7.02	6.96	7.10	7.31	7.54	7.37	7.52	7.75	8.00	7.74	7.90	8.14	8.40	8.04	8.22	8.47	8.75	8.04	8.22	8.47	8.75	8.31	8.49	8.76	9.04
	Amps	13.3	13.5	13.8	14.1	14.0	14.2	14.5	14.9	14.8	15.1	15.4	15.8	15.5	15.8	16.2	16.6	16.3	16.6	17.0	17.4	16.3	16.6	17.0	17.4	17.0	17.3	17.7	18.2
	HI PR	236	254	268	280	265	285	301	314	301	324	342	357	343	369	390	407	386	415	439	458	386	415	439	458	427	459	485	506
3825	LO PR	109	116	127	135	116	123	134	143	120	128	139	149	126	134	146	156	132	141	154	163	132	141	154	163	137	145	159	169
	MBh	93.8	96.6	104.6	112.3	91.7	94.4	102.2	109.6	89.5	92.1	99.7	107.0	87.3	89.9	97.3	104.4	82.9	85.4	92.4	99.2	82.9	85.4	92.4	99.2	76.8	79.1	85.6	91.9
	S/T	0.83	0.75	0.56	0.36	0.86	0.77	0.58	0.38	0.89	0.79	0.60	0.39	0.91	0.82	0.62	0.40	0.95	0.85	0.64	0.41	0.95	0.85	0.64	0.41	0.96	0.86	0.65	0.42
	ΔT	21	19	16	11	21	20	16	11	21	20	16	11	22	20	16	11	21	20	16	11	21	20	16	11	20	18	15	10
	kW	6.44	6.57	6.76	6.97	6.91	7.05	7.26	7.48	7.31	7.46	7.69	7.94	7.67	7.84	8.08	8.34	7.98	8.15	8.41	8.68	7.98	8.15	8.41	8.68	8.25	8.42	8.69	8.97
3400	Amps	13.2	13.4	13.7	14.0	13.9	14.1	14.5	14.8	14.7	15.0	15.3	15.7	15.4	15.7	16.1	16.5	16.2	16.4	16.8	17.3	16.2	16.4	16.8	17.3	16.9	17.2	17.6	18.1
	HI PR	234	252	266	277	262	282	298	311	298	321	339	354	340	366	386	403	382	411	434	453	382	411	434	453	422	454	480	501
	LO PR	108	115	126	134	114	122	133	141	119	126	138	147	125	133	145	154	131	139	152	162	131	139	152	162	135	144	157	167
	MBh	86.6	89.2	96.5	103.6	84.6	87.1	94.3	101.2	82.6	85.0	92.0	98.8	80.6	83.0	89.8	96.4	76.5	78.8	85.3	91.6	76.5	78.8	85.3	91.6	70.9	73.0	79.0	84.8
	S/T	0.80	0.72	0.54	0.35	0.83	0.74	0.56	0.36	0.85	0.76	0.58	0.37	0.88	0.79	0.60	0.38	0.91	0.82	0.62	0.40	0.91	0.82	0.62	0.40	0.92	0.83	0.62	0.40
2720	ΔT	24	22	18	12	24	22	18	12	24	22	18	12	24	22	18	13	24	22	18	12	24	22	18	12	22	20	17	12
	kW	6.30	6.42	6.61	6.81	6.75	6.88	7.09	7.31	7.14	7.29	7.51	7.75	7.49	7.65	7.89	8.14	7.79	7.96	8.20	8.47	7.79	7.96	8.20	8.47	8.05	8.22	8.48	8.75
	Amps	12.9	13.2	13.4	13.8	13.6	13.9	14.2	14.5	14.4	14.7	15.0	15.4	15.1	15.4	15.8	16.2	15.8	16.1	16.5	17.0	15.8	16.1	16.5	17.0	16.5	16.8	17.2	17.7
	HI PR	227	244	258	269	254	274	289	302	289	311	329	343	330	355	375	391	371	399	421	439	371	399	421	439	410	441	466	486
	LO PR	105	112	122	130	111	118	129	137	115	123	134	143	121	129	141	150	127	135	147	157	127	135	147	157	131	140	153	162

IDB: Entering Indoor Dry Bulb Temperature
 High and low pressures are measured at the liquid and suction access fittings.
 Shaded area reflects ACCA (ITVA) Rating Conditions
 Design Superheat 7±2 °F, Design Subcooling 12 ±2 °F pressures measured @ the suction and liquid service ports, AHRI 95 test conditions
 Amps: Unit amps (comp.+ evaporator + condenser fan motors)

COOLING DATA — 8½ TONS (CONT.)

IDB		OUTDOOR AMBIENT TEMPERATURE																								
		65				75				85				95				105				115				
		59	63	67	71	59	63	67	71	59	63	67	71	59	63	67	71	59	63	67	71	59	63	67	71	
		ENTERING INDOOR WET BULB TEMPERATURE																								
		AIRFLOW																								
80	3825	MBh	98.4	100.5	107.4	114.8	96.1	98.2	104.9	112.1	93.8	95.9	102.4	109.5	91.5	93.5	99.9	106.8	86.9	88.8	94.9	101.5	80.5	82.3	87.9	94.0
		S/T	0.96	0.90	0.73	0.55	1.00	0.93	0.76	0.57	1.00	0.96	0.78	0.58	1.00	1.00	0.80	0.60	1.00	1.00	0.83	0.62	1.00	1.00	0.84	0.63
		ΔT	23	22	19	15	23	22	19	15	23	22	19	15	22	22	19	15	21	21	19	15	19	20	18	14
		kW	6.54	6.67	6.87	7.07	7.01	7.15	7.37	7.60	7.43	7.58	7.82	8.06	7.80	7.96	8.21	8.47	8.11	8.28	8.54	8.82	8.38	8.56	8.83	9.12
		Amps	13.3	13.6	13.9	14.2	14.1	14.3	14.6	15.0	14.9	15.2	15.5	16.0	15.6	15.9	16.3	16.8	16.4	16.7	17.1	17.6	17.1	17.4	17.8	18.4
3400		HI PR	238	257	271	283	268	288	304	317	304	328	346	361	347	373	394	411	390	420	443	462	431	464	490	511
		LO PR	110	118	128	137	117	124	136	144	121	129	141	150	127	136	148	158	134	142	155	165	138	147	160	171
		MBh	95.5	97.6	104.3	111.5	93.3	95.3	101.9	108.9	91.1	93.1	99.4	106.3	88.9	90.8	97.0	103.7	84.4	86.3	92.2	98.5	78.2	79.9	85.4	91.2
		S/T	0.91	0.86	0.70	0.52	0.95	0.89	0.72	0.54	0.97	0.91	0.74	0.55	1.00	0.94	0.77	0.57	1.00	0.98	0.79	0.59	1.00	0.98	0.80	0.60
		ΔT	24	23	20	16	24	23	20	16	24	23	20	16	24	23	20	16	23	23	20	16	21	21	18	15
2720		kW	6.49	6.62	6.82	7.02	6.96	7.10	7.31	7.54	7.37	7.52	7.76	8.00	7.74	7.90	8.14	8.40	8.05	8.22	8.47	8.75	8.31	8.49	8.76	9.04
		Amps	13.3	13.5	13.8	14.1	14.0	14.2	14.5	14.9	14.8	15.1	15.4	15.9	15.5	15.8	16.2	16.6	16.3	16.6	17.0	17.4	17.0	17.3	17.7	18.2
		HI PR	236	254	268	280	265	285	301	314	301	324	342	357	343	369	390	407	386	415	439	458	427	459	485	506
		LO PR	109	116	127	135	116	123	134	143	120	128	139	149	126	134	147	156	132	141	154	164	137	145	159	169
		MBh	88.2	90.1	96.2	102.9	86.1	88.0	94.0	100.5	84.1	85.9	91.8	98.1	82.0	83.8	89.5	95.7	77.9	79.6	85.1	90.9	72.2	73.7	78.8	84.2
85		S/T	0.88	0.83	0.67	0.50	0.91	0.86	0.70	0.52	0.94	0.88	0.71	0.53	0.97	0.91	0.74	0.55	1.00	0.94	0.77	0.57	1.01	0.95	0.77	0.58
		ΔT	26	25	22	17	27	25	22	18	27	25	22	18	27	26	22	18	26	25	22	18	25	24	21	16
		kW	6.35	6.47	6.66	6.86	6.80	6.94	7.14	7.36	7.20	7.35	7.57	7.81	7.55	7.71	7.95	8.20	7.85	8.02	8.27	8.53	8.11	8.29	8.55	8.82
		Amps	13.0	13.2	13.5	13.9	13.7	14.0	14.3	14.6	14.5	14.8	15.1	15.5	15.2	15.5	15.9	16.3	15.9	16.2	16.6	17.0	16.6	16.9	17.3	17.8
		HI PR	229	246	260	271	257	277	292	305	292	315	332	346	333	358	378	395	375	403	426	444	414	445	470	490
3825		LO PR	106	113	123	131	112	119	130	139	116	124	135	144	122	130	142	151	128	136	149	159	133	141	154	164
		MBh	100.1	102.0	106.9	114.0	97.8	99.7	104.4	111.4	95.4	97.3	101.9	108.7	93.1	94.9	99.4	106.1	88.5	90.2	94.4	100.8	81.9	83.5	87.5	93.3
		S/T	1.00	0.97	0.87	0.71	1.00	1.00	0.91	0.74	1.00	1.00	0.93	0.75	1.00	1.00	0.96	0.78	1.00	1.00	1.00	0.81	1.00	1.00	1.00	0.81
		ΔT	24	24	22	19	24	24	23	20	23	23	23	20	22	23	23	20	21	22	23	20	20	20	21	18
		kW	6.59	6.72	6.92	7.13	7.06	7.21	7.43	7.66	7.49	7.64	7.88	8.13	7.86	8.02	8.27	8.54	8.17	8.35	8.61	8.89	8.45	8.63	8.90	9.19
3400		Amps	13.4	13.6	14.0	14.3	14.2	14.4	14.7	15.1	15.0	15.3	15.6	16.1	15.7	16.0	16.4	16.9	16.5	16.8	17.2	17.7	17.2	17.5	18.0	18.5
		HI PR	241	259	274	285	270	291	307	320	307	331	349	364	350	377	398	415	394	424	448	467	435	468	495	516
		LO PR	112	119	130	138	118	125	137	146	122	130	142	152	129	137	149	159	135	143	157	167	139	148	162	173
		MBh	97.2	99.1	103.8	110.7	94.9	96.8	101.3	108.1	92.7	94.5	98.9	105.5	90.4	92.2	96.5	103.0	85.9	87.5	91.7	97.8	79.6	81.1	84.9	90.6
		S/T	0.96	0.92	0.83	0.68	0.99	0.96	0.86	0.70	1.00	0.98	0.89	0.72	1.00	1.00	0.92	0.74	1.00	1.00	0.95	0.77	1.00	1.00	0.96	0.78
2720		ΔT	25	25	23	20	25	25	24	21	25	25	24	21	24	25	24	21	23	24	24	20	22	22	22	19
		kW	6.54	6.67	6.87	7.07	7.01	7.15	7.37	7.60	7.43	7.58	7.82	8.06	7.80	7.96	8.21	8.47	8.11	8.28	8.54	8.82	8.38	8.56	8.83	9.12
		Amps	13.3	13.6	13.9	14.2	14.1	14.3	14.6	15.0	14.9	15.2	15.5	16.0	15.6	15.9	16.3	16.8	16.4	16.7	17.1	17.6	17.1	17.4	17.8	18.4
		HI PR	238	257	271	283	268	288	304	317	304	328	346	361	347	373	394	411	390	420	443	462	431	464	490	511
		LO PR	110	118	128	137	117	124	136	144	121	129	141	150	127	136	148	158	134	142	155	165	138	147	160	171
85		MBh	89.7	91.4	95.8	102.2	87.6	89.3	93.5	99.8	85.5	87.2	91.3	97.4	83.4	85.1	89.1	95.0	79.3	80.8	84.6	90.3	73.4	74.9	78.4	83.6
		S/T	0.92	0.89	0.80	0.65	0.96	0.92	0.83	0.68	0.98	0.95	0.85	0.69	1.00	0.98	0.88	0.72	1.00	1.00	0.92	0.74	1.00	1.00	0.92	0.75
		ΔT	28	28	26	23	28	28	26	23	28	28	26	23	28	28	27	23	27	27	26	23	25	25	24	21
		kW	6.39	6.52	6.71	6.91	6.85	6.99	7.20	7.42	7.26	7.40	7.63	7.87	7.61	7.77	8.01	8.27	7.92	8.08	8.34	8.60	8.18	8.35	8.62	8.89
		Amps	13.1	13.3	13.6	13.9	13.8	14.0	14.4	14.7	14.6	14.9	15.2	15.6	15.3	15.6	16.0	16.4	16.0	16.3	16.7	17.2	16.7	17.0	17.5	18.0
	HI PR	231	249	263	274	260	279	295	308	295	318	335	350	336	362	382	399	378	407	430	448	418	450	475	495	
	LO PR	107	114	124	133	113	120	131	140	118	125	137	146	124	131	144	153	130	138	150	160	134	143	156	166	

IDB: Entering Indoor Dry Bulb Temperature
 High and low pressures are measured at the liquid and suction access fittings.
 Shaded area reflects AHRI Rating Conditions
 Design Superheat 7±2 °F. Design Subcooling 12±2 °F pressures measured @ the suction and liquid service ports, AHRI 95 test conditions
 Amps: Unit amps (comp.+ evaporator + condenser fan motors)

COOLING DATA — 10 TONS

IDB		OUTDOOR AMBIENT TEMPERATURE																																			
		65						75						85						95						105						115					
		AIRFLOW				ENTERING INDOOR WET BULB TEMPERATURE				ENTERING INDOOR WET BULB TEMPERATURE				ENTERING INDOOR WET BULB TEMPERATURE				ENTERING INDOOR WET BULB TEMPERATURE				ENTERING INDOOR WET BULB TEMPERATURE				ENTERING INDOOR WET BULB TEMPERATURE											
70	4500	MBh	115.6	119.8	131.3	-	112.9	117.1	128.3	-	110.3	114.3	125.2	-	107.6	111.5	122.1	-	102.2	105.9	116.0	-	94.7	98.1	107.5	-											
		S/T	0.74	0.62	0.43	-	0.77	0.64	0.45	-	0.79	0.66	0.46	-	0.82	0.68	0.47	-	0.85	0.71	0.49	-	0.85	0.71	0.49	-											
		ΔT	18	15	12	-	18	15	12	-	18	15	12	-	18	16	12	-	18	15	12	-	17	14	11	-											
		Hi Pr	246	264	279	-	276	297	313	-	314	337	356	-	357	384	406	-	402	432	457	-	444	478	504	-											
		Lo Pr	107	114	124	-	113	120	131	-	118	125	137	-	124	131	144	-	130	138	150	-	134	143	156	-											
		MBh	112.3	116.4	127.5	-	109.7	113.7	124.5	-	107.0	110.9	121.6	-	104.4	108.2	118.6	-	99.2	102.8	112.7	-	91.9	95.3	104.4	-											
	S/T	0.71	0.59	0.41	-	0.73	0.61	0.43	-	0.75	0.63	0.44	-	0.78	0.65	0.45	-	0.81	0.67	0.47	-	0.81	0.68	0.47	-												
	ΔT	18	16	12	-	19	16	12	-	19	16	12	-	19	16	12	-	18	16	12	-	17	15	11	-												
	Hi Pr	243	262	276	-	273	294	310	-	310	334	353	-	354	381	402	-	398	428	452	-	440	473	499	-												
	Lo Pr	106	113	123	-	112	119	130	-	116	124	135	-	122	130	142	-	128	136	149	-	133	141	154	-												
	3200	MBh	103.6	107.4	117.7	-	101.2	104.9	114.9	-	98.8	102.4	112.2	-	96.4	99.9	109.5	-	91.6	94.9	104.0	-	84.8	87.9	96.3	-											
		S/T	0.68	0.57	0.40	-	0.71	0.59	0.41	-	0.73	0.61	0.42	-	0.75	0.63	0.43	-	0.78	0.65	0.45	-	0.78	0.66	0.45	-											
ΔT		20	18	13	-	21	18	14	-	21	18	14	-	21	18	14	-	20	18	13	-	19	17	13	-												
Hi Pr		236	254	268	-	265	285	301	-	301	324	342	-	343	369	390	-	386	415	438	-	426	459	484	-												
Lo Pr		103	109	120	-	109	116	126	-	113	120	131	-	119	126	138	-	124	132	144	-	129	137	149	-												
MBh		117.6	121.1	131.0	140.6	114.9	118.3	128.0	137.4	112.1	115.4	125.0	134.1	109.4	112.6	121.9	130.8	103.9	107.0	115.8	124.3	96.3	99.1	107.3	115.1												
75	4500	S/T	0.84	0.76	0.57	0.37	0.88	0.78	0.59	0.38	0.90	0.80	0.61	0.39	0.93	0.83	0.63	0.40	0.96	0.86	0.65	0.42	0.97	0.87	0.66	0.42											
		ΔT	20	19	15	11	21	19	16	11	21	19	16	11	21	19	16	11	20	19	15	11	19	18	14	10											
		Hi Pr	248	267	282	294	279	300	316	330	317	341	360	375	361	388	410	428	406	437	461	481	448	483	510	531											
		Lo Pr	108	115	126	134	114	122	133	141	119	126	138	147	125	133	145	154	131	139	152	162	135	144	157	167											
		MBh	114.2	117.5	127.2	136.6	111.5	114.8	124.3	133.4	108.9	112.1	121.3	130.2	106.2	109.3	118.4	127.0	100.9	103.9	112.4	120.7	93.5	96.2	104.2	111.8											
		S/T	0.81	0.72	0.55	0.35	0.84	0.75	0.57	0.36	0.86	0.77	0.58	0.37	0.88	0.79	0.60	0.38	0.92	0.82	0.62	0.40	0.93	0.83	0.63	0.40											
	3200	ΔT	21	19	16	11	21	20	16	11	21	20	16	11	22	20	16	11	21	20	16	11	20	18	15	10											
		Hi Pr	246	264	279	291	276	297	313	327	314	337	356	372	357	384	406	423	402	432	457	476	444	478	505	526											
		Lo Pr	107	114	124	133	113	120	131	140	118	125	137	146	124	131	144	153	130	138	150	160	134	143	156	166											
		MBh	105.4	108.5	117.4	126.0	102.9	106.0	114.7	123.1	100.5	103.4	112.0	120.2	98.0	100.9	109.2	117.2	93.1	95.9	103.8	111.4	86.3	88.8	96.1	103.2											
		S/T	0.78	0.69	0.53	0.34	0.81	0.72	0.55	0.35	0.83	0.74	0.56	0.36	0.85	0.76	0.58	0.37	0.88	0.79	0.60	0.39	0.89	0.80	0.60	0.39											
		ΔT	24	22	18	12	24	22	18	12	24	22	18	12	24	22	18	13	24	22	18	12	22	20	17	12											
Hi Pr	238	257	271	283	267	288	304	317	304	327	346	361	346	373	394	411	390	419	443	462	431	463	489	510													
Lo Pr	104	111	121	129	110	117	128	136	114	121	133	141	120	128	139	148	126	134	146	155	130	138	151	161													

IDB: Entering Indoor Dry Bulb Temperature
 High and low pressures are measured at the liquid and suction access fittings.
 Shaded area reflects ACCA (TVA) Rating Conditions
 Design Superheat 7±2 °F; Design Subcooling 12 ±2 °F; pressures measured @ the suction and liquid service ports, AHRI 95 test conditions
 Amps: Unit amps (comp.+ evaporator + condenser fan motors)

COOLING DATA — 10 TONS (CONT.)

IDB		OUTDOOR AMBIENT TEMPERATURE																																			
		65						75						85						95						105						115					
		AIRFLOW				ENTERING INDOOR WET BULB TEMPERATURE				ENTERING INDOOR WET BULB TEMPERATURE				ENTERING INDOOR WET BULB TEMPERATURE				ENTERING INDOOR WET BULB TEMPERATURE				ENTERING INDOOR WET BULB TEMPERATURE				ENTERING INDOOR WET BULB TEMPERATURE											
	59	63	67	71	59	63	67	71	59	63	67	71	59	63	67	71	59	63	67	71	59	63	67	71	59	63	67	71									
80	4500	MBh	119.7	122.3	130.7	139.7	116.9	119.4	127.6	136.4	114.1	116.6	124.6	133.2	111.3	113.8	121.5	129.9	105.8	108.1	115.5	123.4	105.8	108.1	115.5	123.4	98.0	100.1	107.0	114.3							
		S/T	0.93	0.87	0.71	0.53	0.96	0.90	0.73	0.55	1.00	0.92	0.75	0.56	1.00	0.95	0.78	0.58	1.00	1.00	1.00	0.81	0.60	1.00	1.00	0.81	0.60	1.00	1.00	0.81	0.61						
		ΔT	23	22	19	15	23	22	19	15	23	22	19	15	23	22	19	15	23	22	22	19	15	22	22	19	15	20	20	18	14						
	4000	Hi Pr	251	270	285	297	281	303	320	333	320	344	364	379	364	392	414	432	410	441	466	486	453	487	515	537	453	487	515	537							
		Lo Pr	109	116	127	135	116	123	134	143	120	128	139	148	126	134	146	156	132	141	153	163	137	145	159	169	137	145	159	169							
		MBh	116.2	118.7	126.9	135.6	113.5	116.0	123.9	132.4	110.8	113.2	121.0	129.3	108.1	110.4	118.0	126.1	102.7	104.9	112.1	119.8	102.7	104.9	112.1	119.8	95.1	97.2	103.8	111.0							
	3200	S/T	0.88	0.83	0.67	0.50	0.92	0.86	0.70	0.52	0.94	0.88	0.72	0.54	0.97	0.91	0.74	0.55	1.00	0.94	0.77	0.57	1.00	0.94	0.77	0.57	1.00	0.95	0.77	0.58							
		ΔT	24	23	20	16	24	23	20	16	24	23	20	16	24	23	20	16	24	23	20	16	22	21	18	15	22	21	18	15							
		Hi Pr	248	267	282	294	279	300	317	330	317	341	360	375	361	388	410	428	406	437	461	481	448	483	510	532	448	483	510	532							
	3200	Lo Pr	108	115	126	134	114	122	133	141	119	126	138	147	125	133	145	154	131	139	152	162	135	144	157	167	135	144	157	167							
		MBh	107.2	109.6	117.1	125.2	104.8	107.0	114.4	122.3	102.3	104.5	111.6	119.3	99.8	101.9	108.9	116.4	94.8	96.8	103.5	110.6	94.8	96.8	103.5	110.6	87.8	89.7	95.8	102.5							
		S/T	0.85	0.80	0.65	0.49	0.88	0.83	0.67	0.50	0.91	0.85	0.69	0.52	0.93	0.88	0.71	0.53	0.97	0.91	0.74	0.55	0.97	0.91	0.74	0.55	0.98	0.92	0.75	0.56							
3200	ΔT	26	25	22	17	27	25	22	18	27	25	22	18	27	26	22	18	26	25	22	18	26	25	22	18	25	24	21	16								
	Hi Pr	241	259	274	285	270	291	307	320	307	331	349	364	350	377	398	415	394	424	447	467	435	468	494	516	435	468	494	516								
	Lo Pr	105	112	122	130	111	118	129	137	115	123	134	143	121	129	141	150	127	135	147	157	131	140	152	162	131	140	152	162								
85	4500	MBh	121.8	124.1	130.0	138.7	118.9	121.2	127.0	135.5	116.1	118.4	124.0	132.2	113.3	115.5	120.9	129.0	107.6	109.7	114.9	122.6	107.6	109.7	114.9	122.6	99.7	101.6	106.4	113.5							
		S/T	0.97	0.94	0.85	0.69	1.00	0.97	0.88	0.71	1.00	1.00	0.90	0.73	1.00	1.00	0.93	0.75	1.00	1.00	0.96	0.78	1.00	1.00	0.96	0.78	1.00	1.00	0.97	0.79							
		ΔT	24	24	22	19	24	24	23	20	24	24	23	20	23	24	23	20	22	22	23	20	22	22	23	20	20	21	21	18							
	4000	Hi Pr	253	272	288	300	284	306	323	337	323	348	367	383	368	396	418	436	414	446	471	491	457	492	520	542	457	492	520	542							
		Lo Pr	110	117	128	137	117	124	135	144	121	129	141	150	127	135	148	158	133	142	155	165	138	147	160	171	138	147	160	171							
		MBh	118.2	120.5	126.2	134.7	115.5	117.7	123.3	131.5	112.7	114.9	120.3	128.4	110.0	112.1	117.4	125.3	104.5	106.5	111.5	119.0	104.5	106.5	111.5	119.0	96.8	98.7	103.3	110.2							
	3200	S/T	0.93	0.89	0.81	0.65	0.96	0.93	0.84	0.68	0.98	0.95	0.86	0.70	1.00	0.98	0.89	0.72	1.00	1.00	0.92	0.75	1.00	1.00	0.92	0.75	1.00	1.00	0.93	0.75							
		ΔT	25	25	23	20	25	25	24	21	26	25	24	21	25	25	24	21	24	24	24	20	24	24	24	20	22	23	22	19							
		Hi Pr	251	270	285	297	281	303	320	333	320	344	364	379	364	392	414	432	410	441	466	486	453	487	515	537	453	487	515	537							
	3200	Lo Pr	109	116	127	135	116	123	134	143	120	128	139	148	126	134	146	156	132	141	153	163	137	145	159	169	137	145	159	169							
		MBh	109.1	111.2	116.5	124.3	106.6	108.6	113.8	121.4	104.0	106.1	111.1	118.5	101.5	103.5	108.4	115.6	96.4	98.3	103.0	109.8	96.4	98.3	103.0	109.8	89.3	91.1	95.4	101.7							
		S/T	0.89	0.86	0.78	0.63	0.93	0.89	0.81	0.65	0.95	0.92	0.83	0.67	0.98	0.95	0.85	0.69	1.00	0.98	0.89	0.72	1.00	0.98	0.89	0.72	1.00	0.99	0.89	0.72							
3200	ΔT	28	28	26	23	28	28	26	23	28	28	26	23	29	28	27	23	28	28	26	23	28	28	26	23	26	26	24	21								
	Hi Pr	243	262	276	288	273	294	310	323	310	334	353	368	353	380	402	419	398	428	452	471	439	473	499	521	439	473	499	521								
	Lo Pr	106	113	123	131	112	119	130	139	116	124	135	144	122	130	142	151	128	136	149	159	133	141	154	164	133	141	154	164								

IDB: Entering Indoor Dry Bulb Temperature
 High and low pressures are measured at the liquid and suction access fittings.
 Shaded area reflects AHRI Rating Conditions
 Design Superheat 7±2 °F; Design Subcooling 12 ±2 °F; pressures measured @ the suction and liquid service ports, AHRI 95 test conditions
 Amps: Unit amps (comp.+ evaporator + condenser fan motors)

HEATING DATA

GCH090xxxxxxxx

	OUTDOOR AMBIENT TEMPERATURE																	
	65	60	55	50	47	45	40	35	30	25	20	17	15	10	5	0	-5	-10
MBh	113.1	107.1	100.8	94.2	90.0	87.2	81.0	74.7	66.0	61.0	56.1	53.0	51.0	45.8	40.6	35.4	30.2	24.8
T/R	34.9	33.1	31.1	29.1	27.8	26.9	25.0	23.1	20.4	18.8	17.3	16.4	15.8	14.1	12.5	10.9	9.3	7.6
kW	8.31	8.15	7.99	7.82	7.73	7.66	7.51	7.34	6.42	6.28	6.14	6.06	6.00	5.86	5.72	5.59	5.44	5.31
Amps	19.6	18.5	17.5	16.7	16.3	16.0	15.3	14.8	14.3	13.8	13.4	13.2	13.0	12.6	12.0	11.5	11.0	10.3
COP	3.98	3.85	3.69	3.52	3.41	3.33	3.16	2.98	3.01	2.84	2.68	2.56	2.49	2.29	2.08	1.85	1.62	1.36
EER	13.6	13.1	12.6	12.0	11.6	11.4	10.8	10.2	10.3	9.7	9.1	8.8	8.5	7.8	7.1	6.3	5.5	4.7
HI PR	459	440	423	404	395	387	372	357	342	327	314	307	301	290	278	267	258	248
LO PR	139	129	121	111	105	101	93	83	75	67	59	54	53	44	38	32	28	22

GCH102xxxxxxxx

	OUTDOOR AMBIENT TEMPERATURE																	
	65	60	55	50	47	45	40	35	30	25	20	17	15	10	5	0	-5	-10
MBh	128.2	121.4	114.2	106.8	102.0	98.8	91.8	84.7	71.0	65.6	60.4	57.0	54.9	49.2	43.7	38.1	32.5	26.6
T/R	34.9	33.1	31.1	29.1	27.8	26.9	25.0	23.1	19.3	17.9	16.4	15.5	14.9	13.4	11.9	10.4	8.8	7.2
kW	8.56	8.39	8.23	8.06	7.97	7.90	7.74	7.58	6.04	5.91	5.79	5.72	5.67	5.55	5.42	5.30	5.18	5.05
Amps	19.5	18.3	17.4	16.6	16.2	16.0	15.3	14.7	14.3	13.8	13.4	13.2	13.0	12.6	12.0	11.6	11.0	10.3
COP	4.39	4.23	4.06	3.88	3.75	3.66	3.47	3.27	3.44	3.24	3.05	2.92	2.83	2.60	2.36	2.10	1.84	1.54
EER	15.0	14.5	13.9	13.2	12.8	12.5	11.9	11.2	11.8	11.1	10.4	10.0	9.7	8.9	8.1	7.2	6.3	5.3
HI PR	459	440	423	404	395	387	372	357	342	327	314	307	301	290	278	267	258	248
LO PR	139	129	121	111	105	101	93	83	75	67	59	54	53	44	38	32	28	22

GCH120xxxxxxxx

	OUTDOOR AMBIENT TEMPERATURE																	
	65	60	55	50	47	45	40	35	30	25	20	17	15	10	5	0	-5	-10
MBh	150.8	142.8	134.4	125.6	120.0	116.3	108.0	99.6	87.7	81.0	74.6	70.4	67.8	60.8	53.9	47.0	40.1	32.9
T/R	34.9	33.1	31.1	29.1	27.8	26.9	25.0	23.1	20.3	18.7	17.3	16.3	15.7	14.1	12.5	10.9	9.3	7.6
kW	10.70	10.50	10.31	10.11	10.00	9.92	9.73	9.54	8.65	8.47	8.30	8.20	8.13	7.95	7.78	7.61	7.44	7.27
Amps	41.3	38.9	36.9	35.3	34.3	33.8	32.4	31.2	30.2	29.3	28.3	27.8	27.6	26.6	25.4	24.4	23.3	21.8
COP	4.13	3.98	3.82	3.64	3.51	3.43	3.25	3.06	2.97	2.80	2.63	2.51	2.44	2.24	2.03	1.81	1.58	1.32
EER	14.1	13.6	13.0	12.4	12.0	11.7	11.1	10.4	10.1	9.6	9.0	8.6	8.3	7.6	6.9	6.2	5.4	4.5
Hi Pr	439	421	405	387	378	371	356	342	328	313	301	293	288	277	266	256	246	238
Lo Pr	133	123	115	106	100	96	89	79	71	64	56	52	50	42	37	31	27	21

Above information is for nominal CFM and 70 degree indoor dry bulb. Instantaneous capacity listed.

KW = Total system power

High pressure is measured at the liquid line gauge port connection

AMPS = unit amps (comp.+fans)

AIRFLOW DATA — 7½ TONS

STANDARD BELT DRIVE — HORIZONTAL

ESP (" W.C.)	TURNS OPEN																	
	0			1			2			3			4			5		
	CFM	RPM	BHP	CFM	RPM	BHP	CFM	RPM	BHP	CFM	RPM	BHP	CFM	RPM	BHP	CFM	RPM	BHP
0.1	---	---	---	---	---	---	---	---	---	---	---	---	3434	745	0.96	3264	701	0.79
0.3	---	---	---	---	---	---	---	---	---	3424	800	1.05	3165	747	0.90	2921	704	0.79
0.5	---	---	---	---	---	---	3496	850	1.14	3102	803	0.92	2785	749	0.83	2545	706	0.66
0.7	---	---	---	3397	900	1.32	3158	851	1.06	2735	805	0.82	2345	753	0.73	---	---	---
0.9	3440	946	1.44	3079	901	1.16	2778	855	1.01	---	---	---	---	---	---	---	---	
1.1	3122	948	1.27	2745	906	1.07	2382	857	0.86	---	---	---	---	---	---	---	---	
1.3	---	---	---	---	---	---	---	---	---	---	---	---	---	---	---	---	---	

HIGH-STATIC BELT DRIVE — HORIZONTAL

ESP (" W.C.)	TURNS OPEN																	
	0			1			2			3			4			5		
	CFM	RPM	BHP	CFM	RPM	BHP	CFM	RPM	BHP	CFM	RPM	BHP	CFM	RPM	BHP	CFM	RPM	BHP
0.7	---	---	---	---	---	---	---	---	---	---	---	---	3446	902	1.26	3098	849	1.11
0.9	---	---	---	---	---	---	---	---	---	---	---	---	3110	905	1.17	2745	851	0.96
1.1	---	---	---	---	---	---	---	---	---	3200	963	1.37	2769	909	1.09	---	---	---
1.3	---	---	---	---	---	---	3256	1017	1.66	2889	964	1.31	---	---	---	---	---	---
1.5	---	---	---	3443	1087	1.91	2923	1022	1.47	---	---	---	---	---	---	---	---	---
1.7	3586	1129	2.18	3038	1081	1.62	2509	1029	1.28	---	---	---	---	---	---	---	---	---
1.9	3221	1137	1.87	2588	1073	1.50	---	---	---	---	---	---	---	---	---	---	---	---
2.1	2827	1144	1.71	---	---	---	---	---	---	---	---	---	---	---	---	---	---	---

STANDARD BELT DRIVE — DOWN SHOT

ESP (" W.C.)	TURNS OPEN																	
	0			1			2			3			4			5		
	CFM	RPM	BHP	CFM	RPM	BHP	CFM	RPM	BHP	CFM	RPM	BHP	CFM	RPM	BHP	CFM	RPM	BHP
0.1	---	---	---	---	---	---	---	---	---	---	---	---	3481	747	0.95	3240	698	0.78
0.3	---	---	---	---	---	---	---	---	---	3498	795	1.09	3197	748	0.88	2889	702	0.71
0.5	---	---	---	---	---	---	3414	844	1.22	3091	796	0.91	2837	749	0.79	2491	701	0.59
0.7	3720	935	1.58	3414	889	1.35	3060	845	1.14	2715	800	0.85	---	---	---	---	---	---
0.9	3351	940	1.45	3066	894	1.18	2688	847	0.99	---	---	---	---	---	---	---	---	---
1.1	3114	942	1.34	2677	896	1.05	---	---	---	---	---	---	---	---	---	---	---	---
1.3	---	---	---	---	---	---	---	---	---	---	---	---	---	---	---	---	---	---

HIGH-STATIC BELT DRIVE — DOWN SHOT

ESP (" W.C.)	TURNS OPEN																	
	0			1			2			3			4			5		
	CFM	RPM	BHP	CFM	RPM	BHP	CFM	RPM	BHP	CFM	RPM	BHP	CFM	RPM	BHP	CFM	RPM	BHP
0.7	---	---	---	---	---	---	---	---	---	---	---	---	3428	900	1.25	3045	846	1.06
0.9	---	---	---	---	---	---	---	---	---	3521	958	1.49	3084	905	1.14	2679	850	0.95
1.1	---	---	---	---	---	---	---	---	---	3181	964	1.31	2756	908	1.06	---	---	---
1.3	---	---	---	---	---	---	3358	1020	1.59	2885	967	1.22	---	---	---	---	---	---
1.5	---	---	---	3470	1075	1.81	2950	1024	1.40	2452	972	1.13	---	---	---	---	---	---
1.7	3465	1130	2.11	3065	1080	1.67	2492	1030	1.25	---	---	---	---	---	---	---	---	---
1.9	3147	1136	1.89	2706	1087	1.53	---	---	---	---	---	---	---	---	---	---	---	---
2.1	2719	1142	1.70	---	---	---	---	---	---	---	---	---	---	---	---	---	---	---

NOTES

- Assume dry coil with filter in place; CFM correction for wet coil = 3%
- Any adjustment made to the blower should not cause the motor to draw more than the motor rated RLA. Applications that exceed the above could require a larger motor. Minimum rated SCFM is 350 per ton.

AIRFLOW DATA — 8½ TONS

STANDARD BELT DRIVE — HORIZONTAL

ESP (" W.C.)	TURNS OPEN																	
	0			1			2			3			4			5		
	CFM	RPM	BHP	CFM	RPM	BHP	CFM	RPM	BHP	CFM	RPM	BHP	CFM	RPM	BHP	CFM	RPM	BHP
0.1	---	---	---	---	---	---	---	---	---	4190	792	1.29	3862	743	1.02	3546	695	0.86
0.3	---	---	---	---	---	---	4141	839	1.41	3850	794	1.19	3540	747	1.00	3152	699	0.81
0.5	---	---	---	4057	883	1.46	3759	843	1.27	3471	798	1.12	3175	747	0.91	2692	700	0.67
0.7	4120	934	1.61	3775	894	1.41	3415	846	1.14	3097	800	0.99	2652	752	0.70	---	---	---
0.9	3780	938	1.49	3338	894	1.27	3030	850	1.04	2497	805	0.82	---	---	---	---	---	---
1.1	3311	942	1.36	2904	899	1.06	2375	855	0.87	---	---	---	---	---	---	---	---	---
1.3	---	---	---	---	---	---	---	---	---	---	---	---	---	---	---	---	---	---

HIGH-STATIC BELT DRIVE — HORIZONTAL

ESP (" W.C.)	TURNS OPEN																	
	0			1			2			3			4			5		
	CFM	RPM	BHP	CFM	RPM	BHP	CFM	RPM	BHP	CFM	RPM	BHP	CFM	RPM	BHP	CFM	RPM	BHP
0.7	---	---	---	---	---	---	---	---	---	4157	938	1.73	3462	854	1.24	3338	832	1.15
0.9	---	---	---	---	---	---	4160	969	1.89	3865	941	1.60	3237	873	1.17	2855	838	0.96
1.1	---	---	---	---	---	---	3882	985	1.79	3480	949	1.47	2849	886	1.09	---	---	---
1.3	---	---	---	4082	1053	2.15	3495	999	1.55	3097	957	1.32	---	---	---	---	---	---
1.5	4188	1108	2.38	3760	1061	1.87	3108	1010	1.41	---	---	---	---	---	---	---	---	---
1.7	3884	1117	2.15	3371	1070	1.66	---	---	---	---	---	---	---	---	---	---	---	---
1.9	3499	1126	1.98	---	---	---	---	---	---	---	---	---	---	---	---	---	---	---

STANDARD BELT DRIVE — DOWN SHOT

ESP (" W.C.)	TURNS OPEN																	
	0			1			2			3			4			5		
	CFM	RPM	BHP	CFM	RPM	BHP	CFM	RPM	BHP	CFM	RPM	BHP	CFM	RPM	BHP	CFM	RPM	BHP
0.1	---	---	---	---	---	---	---	---	---	---	---	---	---	---	---	3818	698	1.02
0.3	---	---	---	---	---	---	---	---	---	---	---	---	---	---	---	3450	701	0.84
0.5	---	---	---	---	---	---	---	---	---	3801	795	1.20	3563	773	1.04	3012	704	0.81
0.7	---	---	---	---	---	---	3760	844	1.27	3355	799	1.05	3099	774	0.98	---	---	---
0.9	---	---	---	3724	891	1.44	3350	846	1.17	2707	801	0.90	2497	778	0.78	---	---	---
1.1	3795	947	1.50	3205	897	1.25	2673	851	0.98	---	---	---	---	---	---	---	---	---
1.3	---	---	---	---	---	---	---	---	---	---	---	---	---	---	---	---	---	---

HIGH-STATIC BELT DRIVE — DOWN SHOT

ESP (" W.C.)	TURNS OPEN																	
	0			1			2			3			4			5		
	CFM	RPM	BHP	CFM	RPM	BHP	CFM	RPM	BHP	CFM	RPM	BHP	CFM	RPM	BHP	CFM	RPM	BHP
0.7	---	---	---	---	---	---	---	---	---	---	---	---	---	---	---	3679	830	1.20
0.9	---	---	---	---	---	---	---	---	---	---	---	---	3784	894	1.35	3265	836	1.12
1.1	---	---	---	---	---	---	---	---	---	3833	952	1.59	3247	900	1.23	2742	843	0.94
1.3	---	---	---	---	---	---	3943	1007	1.88	3361	957	1.45	2867	905	1.08	---	---	---
1.5	---	---	---	---	---	---	3522	1012	1.73	2928	962	1.33	---	---	---	---	---	---
1.7	---	---	---	3638	1469	1.99	3018	1020	1.47	---	---	---	---	---	---	---	---	---
1.9	3725	1118	2.24	3018	1078	1.66	---	---	---	---	---	---	---	---	---	---	---	---
2.1	3326	1126	2.04	---	---	---	---	---	---	---	---	---	---	---	---	---	---	---

NOTES

- Assume dry coil with filter in place; CFM correction for wet coil = 3%
- Any adjustment made to the blower should not cause the motor to draw more than the motor rated RLA. Applications that exceed the above could require a larger motor. Minimum rated SCFM is 350 per ton.

AIRFLOW DATA — 10 TONS

STANDARD BELT DRIVE — HORIZONTAL

ESP (" W.C.)	TURNS OPEN																	
	0			1			2			3			4			5		
	CFM	RPM	BHP	CFM	RPM	BHP	CFM	RPM	BHP	CFM	RPM	BHP	CFM	RPM	BHP	CFM	RPM	BHP
0.1	---	---	---	---	---	---	---	---	---	4190	792	1.29	3862	743	1.02	3546	695	0.86
0.3	---	---	---	---	---	---	4141	839	1.41	3850	794	1.19	3540	747	1.00	3152	699	0.81
0.5	---	---	---	4057	883	1.46	3759	843	1.27	3471	798	1.12	3175	747	0.91	2692	700	0.67
0.7	4120	934	1.61	3775	894	1.41	3415	846	1.14	3097	800	0.99	2652	752	0.70	---	---	---
0.9	3780	938	1.49	3338	894	1.27	3030	850	1.04	2497	805	0.82	---	---	---	---	---	---
1.1	3311	942	1.36	2904	899	1.06	2375	855	0.87	---	---	---	---	---	---	---	---	---
1.3	---	---	---	---	---	---	---	---	---	---	---	---	---	---	---	---	---	---

HIGH-STATIC BELT DRIVE — HORIZONTAL

ESP (" W.C.)	TURNS OPEN																	
	0			1			2			3			4			5		
	CFM	RPM	BHP	CFM	RPM	BHP	CFM	RPM	BHP	CFM	RPM	BHP	CFM	RPM	BHP	CFM	RPM	BHP
0.7	---	---	---	---	---	---	---	---	---	4157	938	1.73	3462	854	1.24	3338	832	1.15
0.9	---	---	---	---	---	---	4160	969	1.89	3865	941	1.60	3237	873	1.17	2855	838	0.96
1.1	---	---	---	---	---	---	3882	985	1.79	3480	949	1.47	2849	886	1.09	---	---	---
1.3	---	---	---	4082	1053	2.15	3495	999	1.55	3097	957	1.32	---	---	---	---	---	---
1.5	4188	1108	2.38	3760	1061	1.87	3108	1010	1.41	---	---	---	---	---	---	---	---	---
1.7	3884	1117	2.15	3371	1070	1.66	---	---	---	---	---	---	---	---	---	---	---	---
1.9	3499	1126	1.98	---	---	---	---	---	---	---	---	---	---	---	---	---	---	---

STANDARD BELT DRIVE — DOWN SHOT

ESP (" W.C.)	TURNS OPEN																	
	0			1			2			3			4			5		
	CFM	RPM	BHP	CFM	RPM	BHP	CFM	RPM	BHP	CFM	RPM	BHP	CFM	RPM	BHP	CFM	RPM	BHP
0.1	---	---	---	---	---	---	---	---	---	---	---	---	---	---	---	3818	698	1.02
0.3	---	---	---	---	---	---	---	---	---	---	---	---	---	---	---	3450	701	0.84
0.5	---	---	---	---	---	---	---	---	---	3801	795	1.20	3563	773	1.04	3012	704	0.81
0.7	---	---	---	---	---	---	3760	844	1.27	3355	799	1.05	3099	774	0.98	---	---	---
0.9	---	---	---	3724	891	1.44	3350	846	1.17	2707	801	0.90	2497	778	0.78	---	---	---
1.1	3795	947	1.50	3205	897	1.25	2673	851	0.98	---	---	---	---	---	---	---	---	---
1.3	---	---	---	---	---	---	---	---	---	---	---	---	---	---	---	---	---	---

HIGH-STATIC BELT DRIVE — DOWN SHOT

ESP (" W.C.)	TURNS OPEN																	
	0			1			2			3			4			5		
	CFM	RPM	BHP	CFM	RPM	BHP	CFM	RPM	BHP	CFM	RPM	BHP	CFM	RPM	BHP	CFM	RPM	BHP
0.7	---	---	---	---	---	---	---	---	---	---	---	---	---	---	---	3679	830	1.20
0.9	---	---	---	---	---	---	---	---	---	---	---	---	3784	894	1.35	3265	836	1.12
1.1	---	---	---	---	---	---	---	---	---	3833	952	1.59	3247	900	1.23	2742	843	0.94
1.3	---	---	---	---	---	---	3943	1007	1.88	3361	957	1.45	2867	905	1.08	---	---	---
1.5	---	---	---	---	---	---	3522	1012	1.73	2928	962	1.33	---	---	---	---	---	---
1.7	---	---	---	3638	1469	1.99	3018	1020	1.47	---	---	---	---	---	---	---	---	---
1.9	3725	1118	2.24	3018	1078	1.66	---	---	---	---	---	---	---	---	---	---	---	---
2.1	3326	1126	2.04	---	---	---	---	---	---	---	---	---	---	---	---	---	---	---

NOTES

- Assume dry coil with filter in place; CFM correction for wet coil = 3%
- Any adjustment made to the blower should not cause the motor to draw more than the motor rated RLA. Applications that exceed the above could require a larger motor. Minimum rated SCFM is 350 per ton.

HEAT KIT ELECTRICAL DATA — 7½ TONS

MODEL AND HEAT KIT USAGE	MCA ¹ AT 400V	MOP ² (AMPS) AT 400V	ACTUAL kW AT 400V	RECOMMENDED AIRFLOW RANGE
GCH090***5B***	20.5	25		
EHK4-30	57.9	60	21	3000-3375 CFM

¹ Minimum Circuit Ampacity

² Maximum Overcurrent Protection device

kW CORRECTION FACTOR

kW CORRECTION FACTOR FOR 400V UNITS		
SUPPLY VOLTAGE	390	380
CORRECTION FACTOR	0.95	0.91

MINIMUM AIRFLOW FOR ELECTRIC HEAT

HEATER SIZE (kW)	MINIMUM CFM
30	3,000

For other voltage, use $\text{voltage}^2 / 400^2$

HEAT KIT ELECTRICAL DATA — 8½ TONS

MODEL AND HEAT KIT USAGE	MCA ¹ AT 400V	MOP ² (AMPS) AT 400V	ACTUAL kW AT 400V	RECOMMENDED AIRFLOW RANGE (DOWNSHOT)	RECOMMENDED AIRFLOW RANGE (HORIZONTAL)
GCH102***5B***	23.9	30			
EHK4-30	61.3	70	21	3400 - 3825 CFM	3400 - 3825 CFM

¹ Minimum Circuit Ampacity

² Maximum Overcurrent Protection device

kW CORRECTION FACTOR

kW CORRECTION FACTOR FOR 400V UNITS		
SUPPLY VOLTAGE	390	380
CORRECTION FACTOR	0.95	0.91

MINIMUM AIRFLOW FOR ELECTRIC HEAT

HEATER SIZE (kW)	MINIMUM CFM
30	3,400

For other voltage, use $\text{voltage}^2 / 400^2$

HEAT KIT ELECTRICAL DATA — 10 TONS

MODEL AND HEAT KIT USAGE	MCA ¹ AT 400V	MOP ² (AMPS) AT 400V	ACTUAL kW AT 400V	RECOMMENDED AIRFLOW RANGE
GCH120***5B***	30.8	40		
EHK4-30	62	70	21	3500 - 4500 CFM

¹ Minimum Circuit Ampacity

² Maximum Overcurrent Protection device

kW CORRECTION FACTOR

kW CORRECTION FACTOR FOR 400V UNITS		
SUPPLY VOLTAGE	390	380
CORRECTION FACTOR	0.95	0.91

MINIMUM AIRFLOW FOR ELECTRIC HEAT

HEATER SIZE (kW)	MINIMUM CFM
30	4,000

For other voltage, use $\text{voltage}^2 / 400^2$

DIMENSIONS

MODEL TONNAGE	"A"	"B"
7.5 TON COMMERCIAL GAS, HT PUMP, AIR CONDITIONER	53.339	20.055
8.5 TON COMMERCIAL GAS, HT PUMP, AIR CONDITIONER	53.339	20.055
10 TON COMMERCIAL GAS, HT PUMP, AIR CONDITIONER	53.339	20.055
12.5 TON COMMERCIAL GAS, HT PUMP, AIR CONDITIONER	58.839	18.055

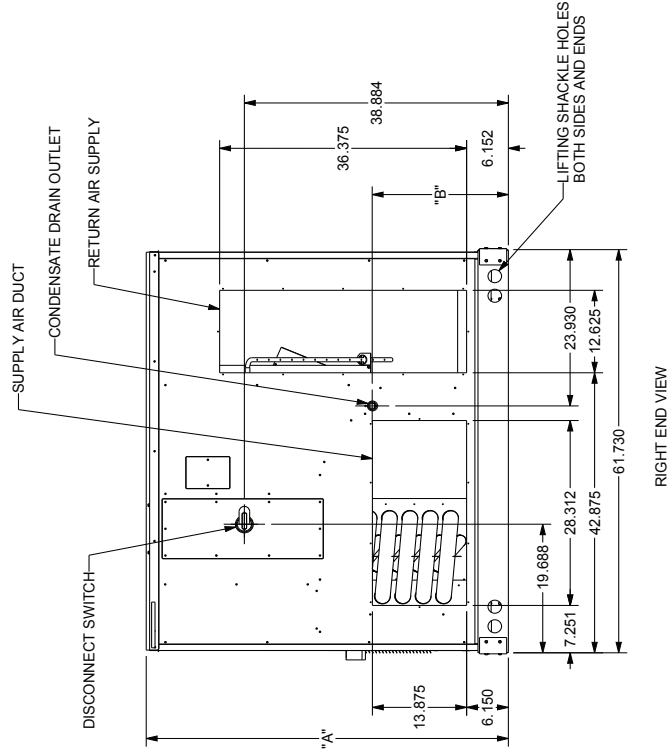
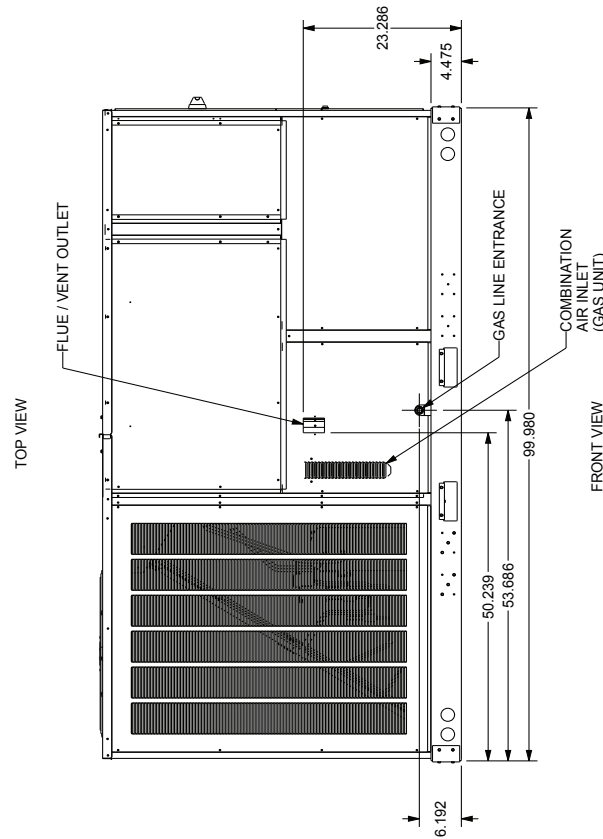
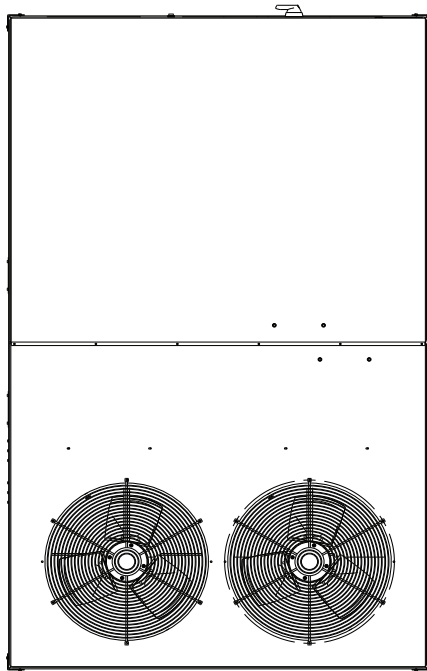

DC*090-150***

7.5 THRU 12.5 TON COMMERCIAL

ALL DIMENSIONS GIVEN ARE IN INCHES
ALL DIMENSIONS AND SPECIFICATIONS ARE SUBJECT TO CHANGE WITHOUT NOTICE

UNIT CLEARANCES

Maintain an adequate clearance around the unit for safety, service, maintenance, and proper unit operation. Leave a total clearance of 75" on the main control panel side of the unit for possible removal of fan shaft, coil, electric heat, and gas furnace. Leave a clearance of 48" on all other sides of the unit for possible compressor removal or service access, and to ensure proper ventilation and condenser airflow. Do not install the unit beneath any obstruction. Install the unit away from all building exhausts to inhibit ingestion of exhaust air into the unit's fresh-air intake.

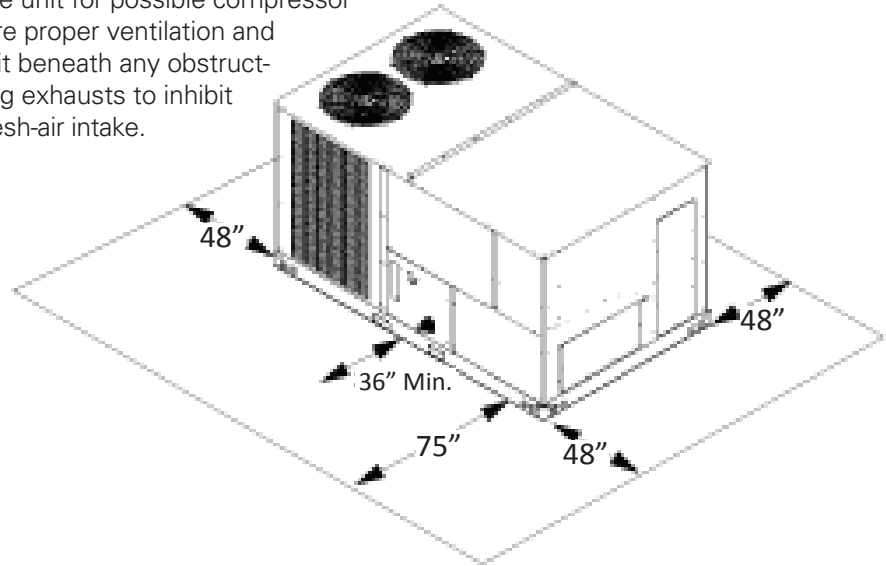

ELECTRICAL ENTRANCE LOCATIONS

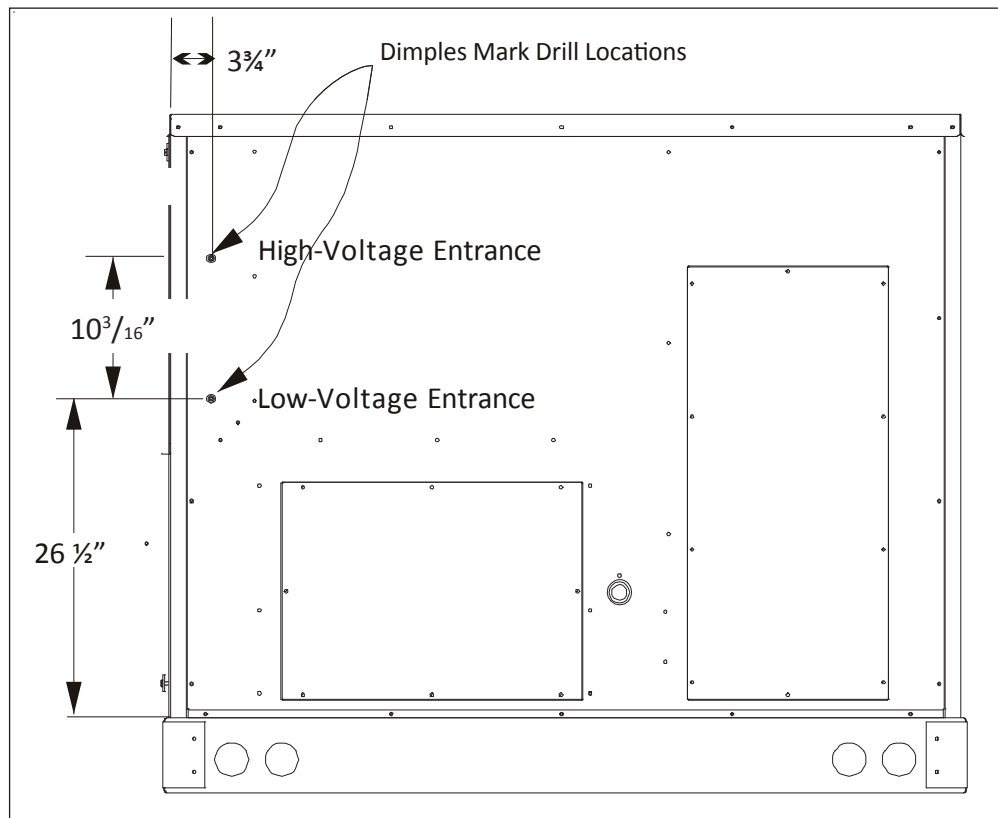

ROOF CURB INSTALLATION — RIGGING

Provisions for forks have been included in the unit base frame. No other fork locations are approved.

- Unit must be lifted by the four lifting holes located at the base frame corners.
- Lifting cables should be attached to the unit with shackles.
- The distance between the crane hook and the top of the unit must not be less than 60”.
- Two spreader bars must span over the unit to prevent damage to the cabinet by the lift cables. Spreader bars must be of sufficient length so that cables do not come in contact with the unit during transport. Remove wood struts mounted beneath unit base frame before setting unit on roof curb. These struts are intended to protect unit base frame from fork lift damage. To remove the struts, extract the sheet metal retainers and pull the struts through the base of the unit. Refer to rigging label on the unit.

Important: If using bottom discharge with roof curb, duct-work should be attached to the curb prior to installing the unit. Duct-work dimensions are shown in Roof Curb Installation Instructions Manual.

Refer to the Roof Curb Installation Instructions for proper curb installation. Curbing must be installed in compliance with the National Roofing Contractors Association Manual.

Lower unit carefully onto roof mounting curb. While rigging the unit, the center of gravity will cause the condenser end to be lower than the supply air end.

Bring condenser end of unit into alignment with the curb. With condenser end of the unit resting on curb member and using curb as a fulcrum, lower opposite end of the unit until entire unit is seated on the curb. When a rectangular cantilever curb is used, take care to center the unit. Check for proper alignment and orientation of supply and return openings with duct.

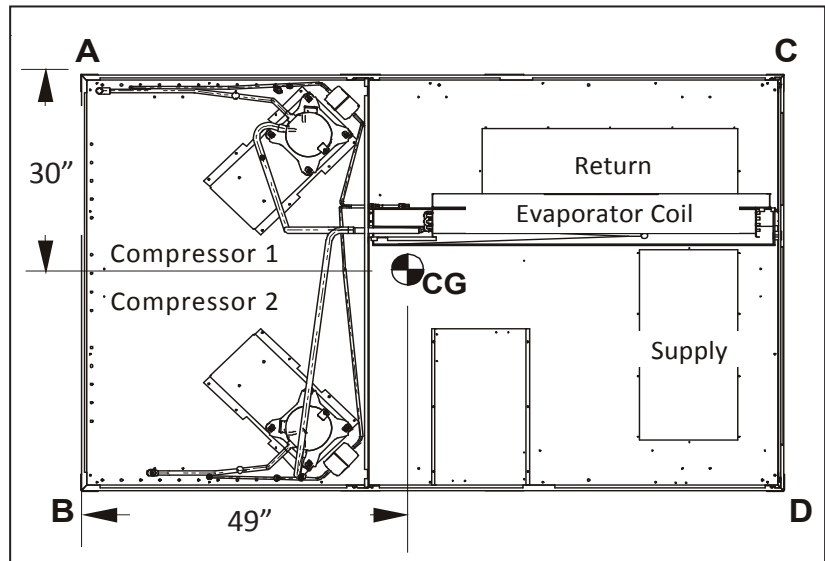
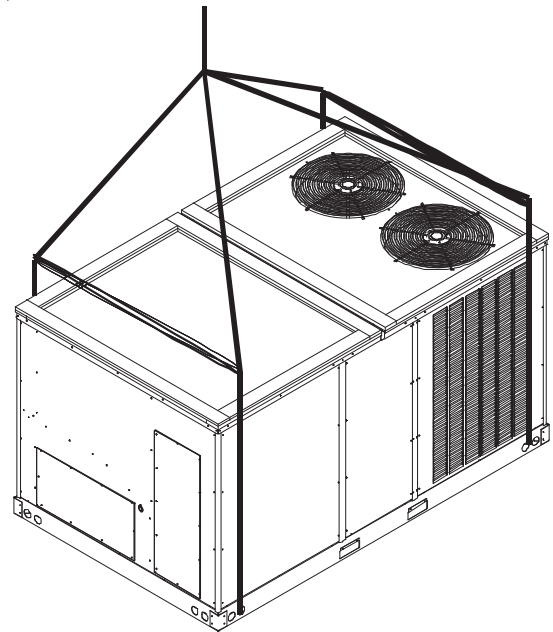

CORNER & CENTER-OF-GRAVITY LOCATIONS

UNIT WEIGHTS	7½-TON WEIGHTS (LBS)	8½-TON WEIGHTS (LBS)	10-TON WEIGHTS (LBS)
Weight A	285	345	345
Weight B	285	325	325
Weight C	285	320	320
Weight D	285	300	300
Shipping Weight	1175	1310	1310
Operating Weight	1135	1285	1285

Note: These weights are calculated without accessories installed.

ROOF CURB INSTALLATION (CONT.)

Curb installations must comply with local codes and should follow the established guidelines of the National Roofing Contractors Association.

Proper unit installation requires that the roof curb be firmly and permanently attached to the roof structure. Check for adequate fastening method prior to setting the unit on the curb.

Full perimeter roof curbs are available from the factory and are shipped unassembled. The installing contractor is responsible for field assembly, squaring, leveling, and mounting on the roof structure. All required hardware necessary for the assembly of the sheet metal curb is included in the curb accessory package.

- Determine sufficient structural support before locating and mounting the curb and package unit.
- Duct-work must be constructed using industry guidelines. The duct-work must be placed into the roof curb before mounting the package unit. Our full perimeter curbs include duct connection frames to be assembled with the curb. Cantilevered-type curbs are not available from the factory.
- Contractor furnishes curb insulation, cant strips, flashing, and general roofing material.
- Support curbs on parallel sides with roof members. To prevent damage to the unit, the roof members cannot penetrate supply and return duct openings.

Note: The unit and curb accessories are designed to allow vertical duct installation before unit placement. Duct installation after unit placement is not recommended.

3-D VIEW

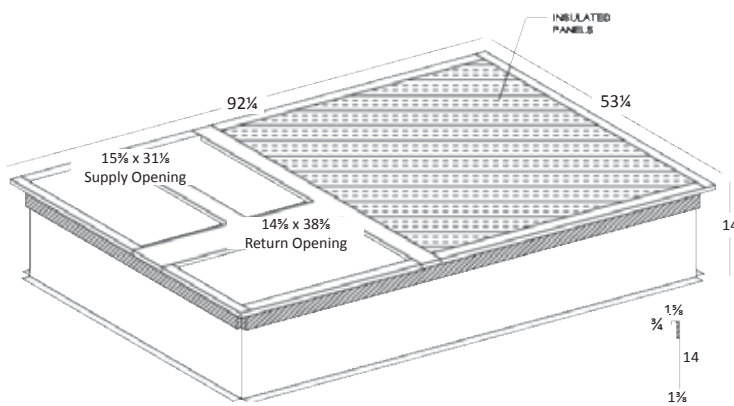

See the manual shipped with the roof curb for assembly and installation instructions.

TOP VIEW

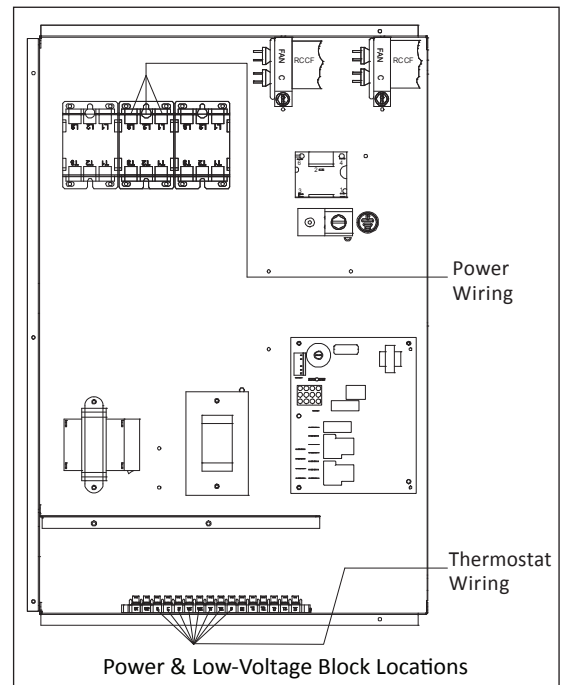
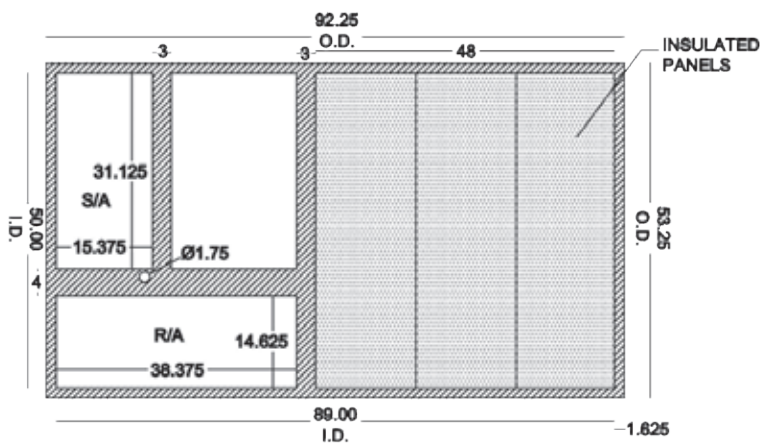

GCH 7½ – 10 TONS (400V/ 50 Hz, THREE-PHASE BELT DRIVE)

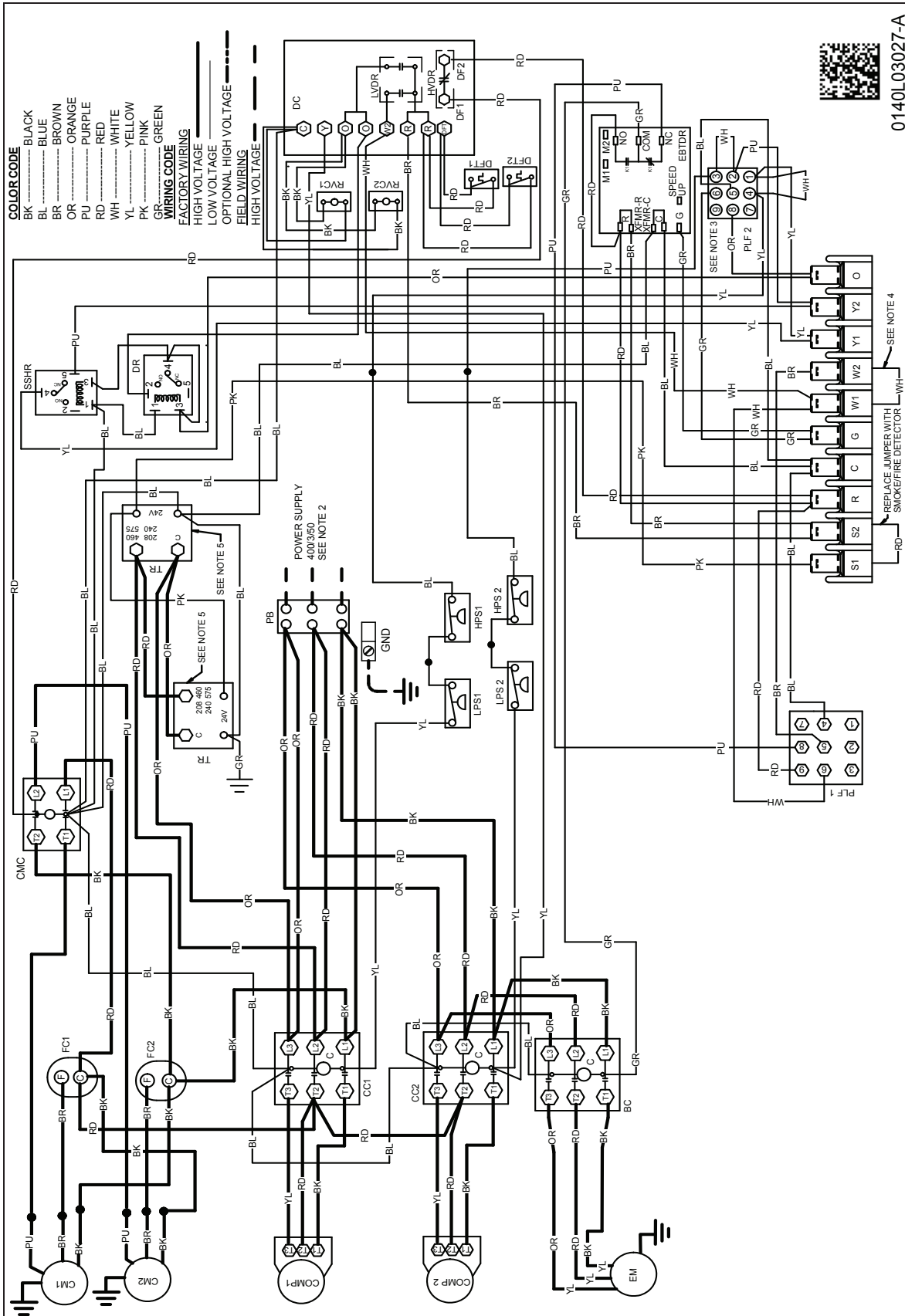

WARNING
 High Voltage: Disconnect all power before servicing or installing this unit. Multiple power sources may be present. Failure to do so may cause property damage, personal injury, or death.

Wiring is subject to change. Always refer to the wiring diagram or the unit for the most up-to-date wiring.

GCH 7½ – 10 TONS (400V/ 50 Hz, THREE-PHASE BELT DRIVE)

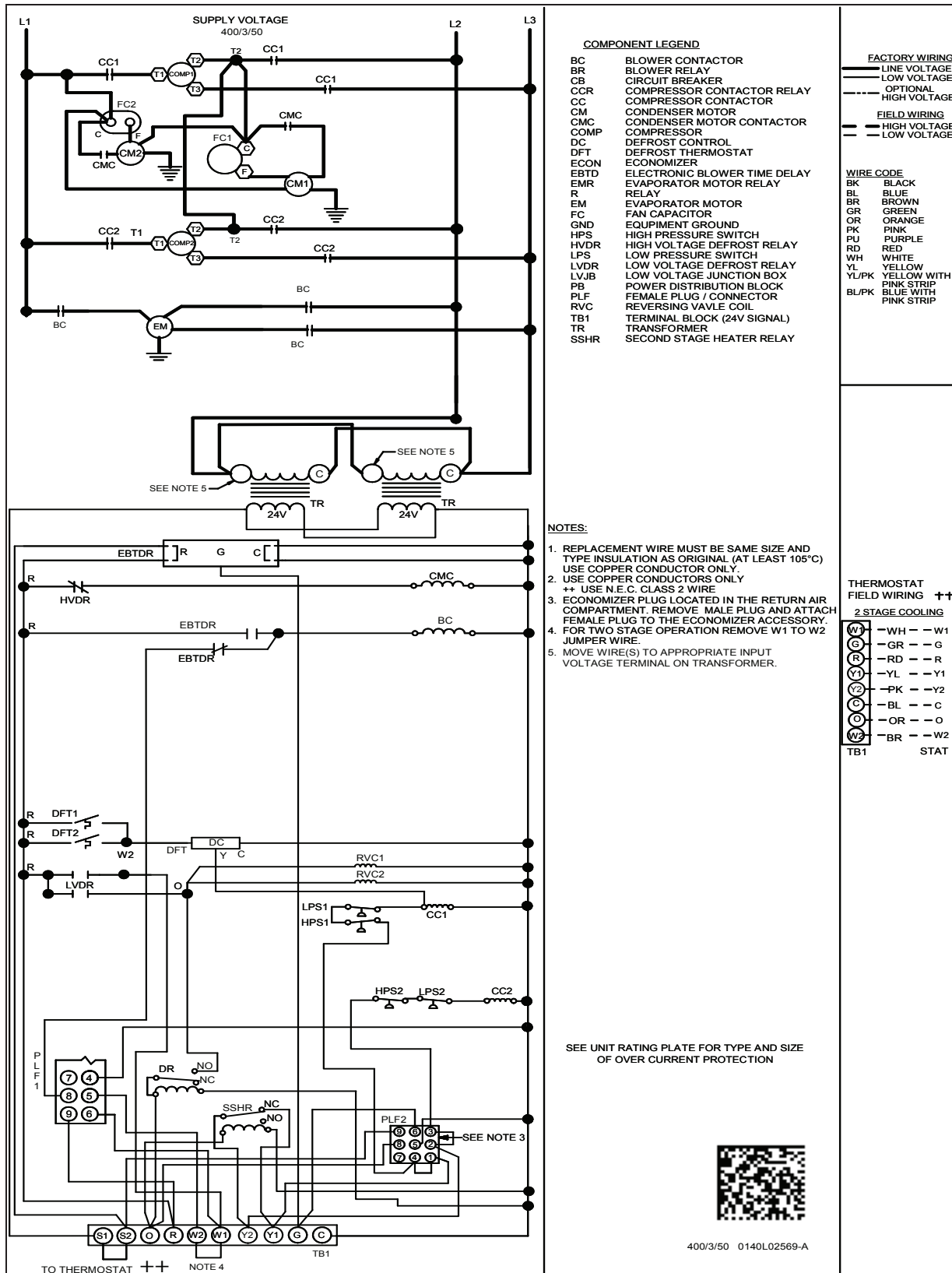

High Voltage: Disconnect all power before servicing or installing this unit. Multiple power sources may be present. Failure to do so may cause property damage, personal injury, or death.

WARNING

Wiring is subject to change. Always refer to the wiring diagram or the unit for the most up-to-date wiring.